



IGMS Financial Tracking

for HI Finance

Overview of IGMS System

The IGMS system is designated for researchers, host institution administrator officers and grant managers who are involved in NRF, MOH, MOE and A*STAR grants.

The system allows management of grants from submission of proposal till closure of the project.

Definitions, Acronyms and Abbreviations

Sl. No	Abbreviation / Acronyms	Definitions
1	PI	Principal Investigator
2	PM	Programme manager
3	AF	Agency Finance
4	HI	Host Institution
5	HI Finance	Host Institution Finance
6	HI HR	Host Institution Human Resources
7	RGO	Research Grant Office
8	EOM	Expenditure of Manpower (Vote or Budget Category)
9	OOE	Other Operating Expenditures (Vote or Budget Category)
10	EQP	Equipment (Vote or Budget Category)
11	RS	Research Scholarship (Vote or Budget Category)
12	OT	Overseas Travel (Vote or Budget Category)
13	SHC	Supplemental Human Capital (Vote or Budget Category)

Definitions, Acronyms and Abbreviations

Sl. No	Abbreviation / Acronyms	Definitions
14	EI	Exceptional Items (Vote or Budget Category)
15	IDC	Indirect Costs Budget
16	IP Comm	IP and Commercialization Budget

Learning Objectives

In this session, you will learn :

- **Overview and Navigation of IGMS**

In this module you will learn how to navigate IGMS as a HI Finance

- **Fund Requisition (Project Claim)**

In this module you will learn how to understand the fund requisition process, fund requisition pages, how to review and complete Fund Requisition or Claim.

- **Cash Flow Projection**

In this module you will learn how to create, submit and review Cash Flow Projection.

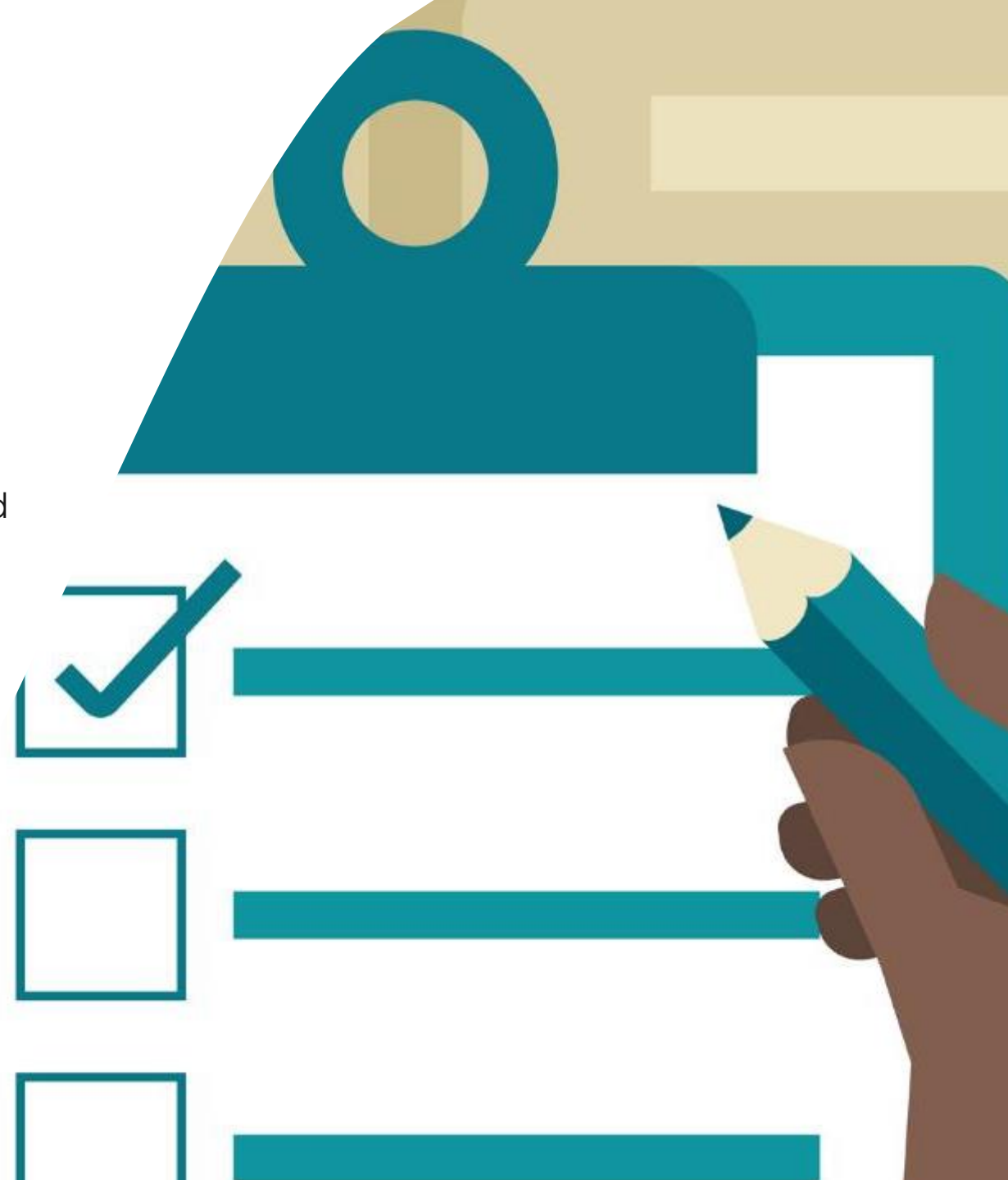

Overview and Navigation of IGMS

1. Overview and Navigation of IGMS

2. Fund Requisition (Project Claim)

- Understanding Fund Requisition
 - Fund Requisition Type
 - Fund Requisition Period (Claim Period)
 - Fund Requisition Status
 - Fund Requisition Pages
 - Fund Requisition Navigation Bar
- Understanding Fund Requisition Upload Process
 - Upload File Validation
 - Business Validation
- Understanding Fund Requisition Approval

Overview and Navigation of IGMS

- Upload and Submit Fund Requisition
 - Advancement
 - Statement of Account
 - Reimbursement
 - Review and Re-upload Fund Requisition (All Methods)
 - Editing calculated IDC for RIE 2015
3. Cash Flow Projection
- Create & Submit Cash Flow Projection
 - Review Cash Flow Projection
4. Download Fund Requisition

Integrated Grant Management System (IGMS)

<https://researchgrant.gov.sg/>

Login in IGMS

Logging in IGMS

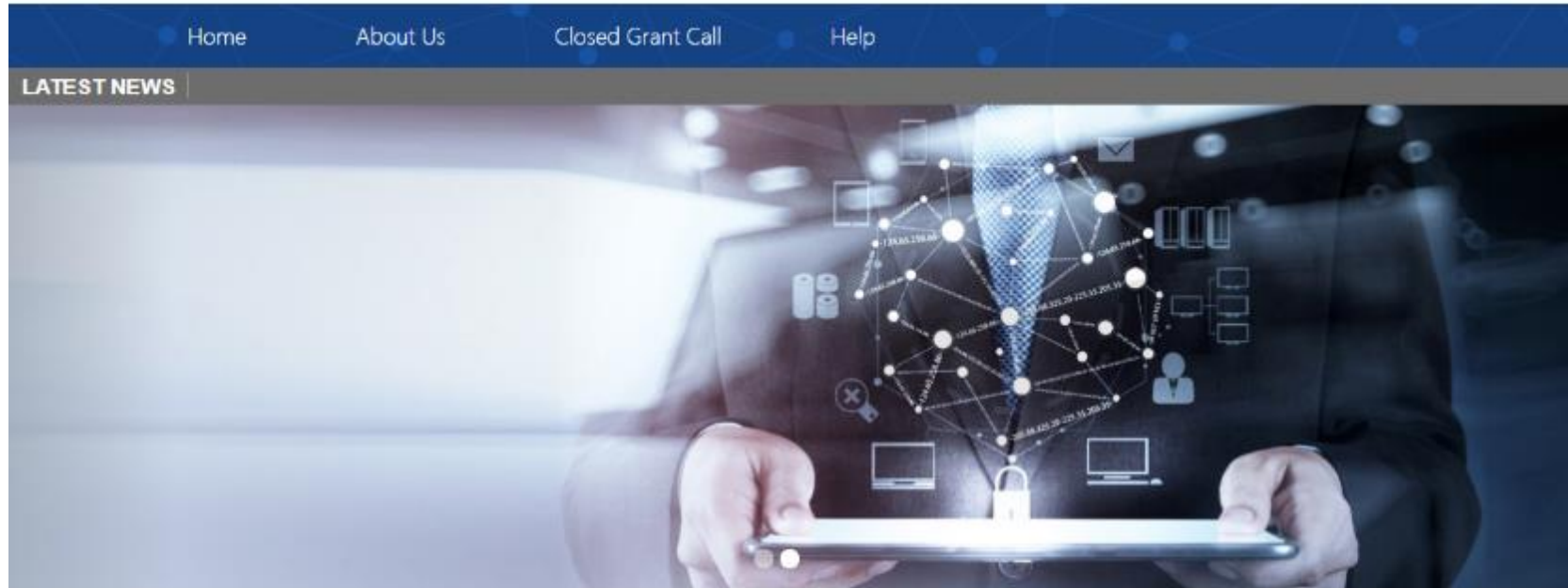

1 Click on **Login**

1

Login

 LOGIN

Subscribe

Open Opportunities

Search

1 of 12 matching results found

< 1 2 3 >

Show 5

Grant Call Name	Managing Organisation	Opening Date	Closing Date
PAX14	Ministry Of Education A*STAR Agency	9-Sep-2017	1-Jan-2019

Logging in IGMS

2



Host Institution Users

- Principal Investigator
- HI Administrator
- Office of Research/ Director of Research
- HI Finance/ HI Human Resource
- Data Administrator/ HI Audit

2

Users performing transactions on behalf of their company should login using the “Host Institution Users” option.

Links and Menus in IGMS

Links and Menus in IGMS



1 Dashboard: Displays the items pending user's actions

2 Projects: Displays the awarded projects and fund requisitions under the user's institution

3 Deviations: Displays all submitted deviation requests

4 Advance Search: Displays the search for Grant Calls, and Awarded Projects

5 User Profile: Displays the user profile like name, id number, nationality, email address, etc.

Links and Menus in IGMS

1

Dashboard Projects - Deviations - Advanced Search - NRF PST HI Finance 2 (HI Finance) ▾

1

Projects

1 - 8 of 8 matching results found

⏪ < 1 > ⏩

Date ▲	Subject	Reference ID	Read
17-Jul-2019	Fund requisition is pending for your amendment. To view details, click on reference ID	NRF-001313	Yes
15-Aug-2019	Fund requisition is pending for your amendment. To view details, click on reference ID	NRF-001351	No
27-Sep-2019	Fund requisition is pending for your amendment. To view details, click on reference ID	NRF-001396	No
07-Jan-2020	Fund requisition is pending for your amendment. To view details, click on reference ID	NRF-002696	No
10-Jan-2020	Fund requisition is pending for your amendment. To view details, click on reference ID	NRF-002703	No
21-Jan-2020	Fund requisition is pending for your amendment. To view details, click on reference ID	NRF-002724	No
25-Mar-2020	Fund requisition is pending for your amendment. To view details, click on reference ID	NRF-002018	No
20-May-2020	Fund requisition is pending for your amendment. To view details, click on reference ID	NRF-002763	No

1



Projects: Displays the awarded projects (post-award) action items.



Overview and Navigation of IGMS



1

2

1 Use the  arrow button to view next page for multiple pages view. And  arrow button to view previous page.

2 Use  arrow button to switch to the last page. And  arrow button to view the first page.

3 Use search box to search a record. A syntax ** (star) can be use to search record like / similar (not exact match)

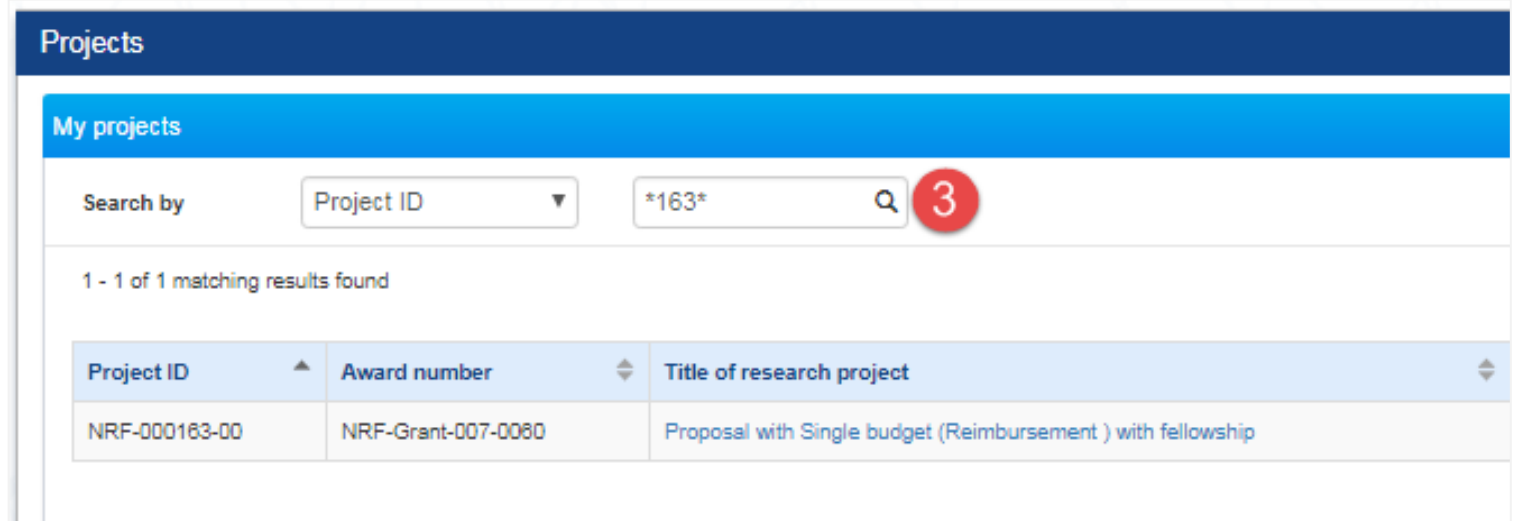

3

Fund Requisition (Project Claim)

1. Overview and Navigation of IGMS
- 2. Fund Requisition (Project Claim)**
 - **Understanding Fund Requisition**
 - Fund Requisition Type
 - Fund Requisition Period (Claim Period)
 - Fund Requisition Status
 - Fund Requisition Pages
 - Fund Requisition Navigation Bar
 - Understanding Fund Requisition Upload Process
 - Upload File Validation
 - Business Validation
 - Understanding Fund Requisition Approval

Fund Requisition

- Upload and Submit Fund Requisition
 - Advancement
 - Statement of Account
 - Reimbursement
 - Review and Re-upload Fund Requisition (All Methods)
 - Editing calculated IDC for RIE 2015
3. Cash Flow Projection
- Create & Submit Cash Flow Projection
 - Review Cash Flow Projection
4. Download Fund Requisition

Fund Requisition Type

Fund Requisition – Fund Requisition Type

There are 2 types of claim method in IGMS :

- Advancement
- Reimbursement

Each claim method will be submitted using these form types :

1. Advancement :

- Regular claims will use the Fund Requisition Advancement format
- For the last claim, use Fund Requisition Statement of Account format
- HI Finance submits the fund requisition in the beginning of each period. Period available for each project are : Quarterly, Yearly, or Half yearly
- HI finance reports the expenditure incurred in the previous quarter/Year/Half yearly using the funds received and the funds required in the current quarter/Year/Half yearly. The system then computes the net amount required.
- Within each period, only 1 fund requisition is allowed for submission.

Fund Requisition – Fund Requisition Type

There are 2 types of claim method in IGMS :

- Advancement
- Reimbursement

Each claim method will be submitted using these form types :

2. Reimbursement :

- In reimbursement mode, HI Finance submits the fund requisition after the HI has incurred the expenses.
- HI Finance submits the fund requisition at the beginning of each quarter for the expenses incurred in the previous quarter.
- Within one period (quarterly), only 1 fund requisition is allowed for submission.
- For both regular and the last claim, use the same form template. For the last claim, system will indicate a flag in the form as Final Claim.

Fund Requisition / Claim Period

Review Fund Requisition – Definition of Last Claim

1 Definition of Last Claim is the claim (or settlement) that can be submitted within 6 months after the project ended. Depending on project start and project end date, there will be a different variation of qualifying dates for last claim.

2 Example for Quarterly Claim Period Project, The Last Claim Date Submission. Project Start 15 Dec 2017 Project End Date 14 Dec 2022

2 15-Dec-2017 – 14-Dec-2018

1st Claim : Oct - Dec 2017
2nd Claim : Jan - Mar 2018
3rd Claim : Mar - Jun 2018
4th Claim : Jul - Sep 2018

15-Dec-2018 – 14-Dec-2019

1st Claim : Oct - Dec 2018
2nd Claim : Jan - Mar 2019
3rd Claim : Mar - Jun 2019
4th Claim : Jul - Sep 2019

15-Dec-2019 – 14-Dec-2020

1st Claim : Oct - Dec 2019
2nd Claim : Jan - Mar 2020
3rd Claim : Mar - Jun 2020
4th Claim : Jul - Sep 2020

15-Dec-2020 – 14-Dec-2021

1st Claim : Oct - Dec 2020
2nd Claim : Jan - Mar 2021
3rd Claim : Mar - Jun 2021
4th Claim : Jul - Sep 2021

15-Dec-2021 – 14-Dec-2022

1st Claim : Oct - Dec 2021
2nd Claim : Jan - Mar 2022
3rd Claim : Mar - Jun 2022
4th Claim : Jul - Sep 2022

15-Dec-2017 – 14-Dec-2022

2

1st Claim :
Oct - 14 Dec 2022
Final Claim :
15 Dec - Jun 2023

1

Fund Requisition Status

Fund Requisition – Understanding Fund Requisition Status

No	Status Name	Description
1	Draft	Initial status when HI Finance creates a Fund Requisition.
2	Pending Workflow Submission	Fund Requisition submitted to system and waiting for workflow approval.
3	Pending HI HR Input	Pending HI HR to input manpower listing for the project.
4	Pending PI Input	This status is only applicable for ASTAR, where the PI needs to verify the claim and input projected expenses to calculate the required amount for advancement claims.
5	Pending Agency Finance Review	This status is when Agency Finance reviews the claim. Agency finance is only able to amend the fundable amount at this status.
6	Pending PM Review	This status is when the FR is pending PM's review and approval. PM is only able to amend fundable amount at this status.
7	Supported	This status is for multilevel projects when the FR is pending multilevel PM approval.
8	Approved Pending Payment	This status appears after PM has approved, if the Fund Request is not multi level approval, or after the last multilevel PM approves the Fund Request. Only fund request with this status can be posted as an expense.

Fund Requisition – Understanding Fund Requisition Status

No	Status Name	Description
9	Pending HI Finance Resubmission	This status is when Agency Finance rejects the claim to the HI Finance. The Fund Request will be returned to the HI Finance for amendment. After amendment, Fund Request will route to HI HR and PI (For ASTAR only) before it is submitted back to Agency Finance.
10	Pending HI HR Resubmission	This status is when Agency Finance rejects the claim to HI HR. The Fund Request will be returned to HI HR for amendment. After amendment, upon resubmission Fund Request will route to: <ul style="list-style-type: none"> • Agency Finance (for NRF,MOE,MOH) or • PI (For ASTAR only) then to the Agency Finance
11	Pending HI Finance Clarification	This status is when Agency Finance returns the Fund Request directly to HI Finance for clarifications. HI Finance would be able to submit the clarifications directly to Agency Finance for review.
12	Pending HI HR Clarification	This status is when Agency Finance returns the Fund Request to HI HR. HI HR would be able to submit the clarifications directly to Agency Finance for review.
13	Pending PI Clarification	This status when PM return Fund Request to PI. PI would be able to submit the clarifications directly to PM for review. PI is unable to make amendment to the Fund Request with this status.

Fund Requisition – Understanding Fund Requisition Status

No	Status Name	Description
14	Clarification Received- Pending Agency Finance Review	This status is when HI Finance or HI HR submits clarification to the Agency Finance.
15	Sent to Payment System	This is the status when IGMS sent the interface file to NRF (applicable to NRF funded projects only)
16	Interface Successful, Pending Processing	This is the status when NRF received the interface file from IGMS. Payment is pending processing. (applicable to NRF funded projects only)
17	Interface Failed, Pending Agency Finance Review	This is the status when NRF sent a failed response file to IGMS. Agency Finance to check the FR for the error message from NRF Payment System. (applicable to NRF funded projects only)
18	Interface Returned, Pending Agency Finance Review	This is the status when NRF sent a return response file to IGMS. Agency Finance to check the FR for the comments from Finance. (applicable to NRF funded projects only)
19	Payment Processed	This is the status when NRF processed the payment successfully (applicable to NRF funded projects only)

Fund Requisition Pages

Fund Requisition – Vote Code (Budget Category)

Fund Requisition contain a maximum on 11 pages. The actual number of page to fill up by uploading the claim file is vary according to the Payment Method (Advancement method or Reimbursement method)

1 Summary Page

2 Expenditure if Manpower (EOM)

3 Other Operating Expenditure (OOE)

4 Equipment (EQP)

5 Overseas Travel (OT)

6 Research Scholarship (RS)

7 Exceptional Items (EI)

8 Supplemental Human Capital (SHC)

9 Commitment OOE

10 Commitment EQP

11 Undertaking

Fund Requisition Navigation Bar

Fund Request Advancement - Submission

1 Navigation bar shown the completeness on each page after uploading file process.

Home > Projects > Submit Claim > Summary

Summary ✓ Expenditure on Manpower (EOM) ✓ Other Operating Expenditure (OOE) ✓ Equipment (EQP) ✓ Overseas Travel (OT) ✓ Research Scholarship (RS) ✓ Exception Items (EI) ✓

Summary Expand All Sections

Hide Fund Details

Fund requisition ID	NRF-001982	Project ID	NRF-000807-01
Financial quarter	FY 2019 Q3	Award number	NRF-t351-0001
Submission date and time	01-Oct-2019	Project start date	01-Sep-2019
Host institution	NUS	Project end date	01-Aug-2021
HI claim no		Lead PI/Team PI	NCS PST PI 2
Status	Pending Review		

Download Fund Request

Summary ✓ Attachments ✓ Action Trail ✓ Download Fund Request ✓

< Back Next

2 Move from each page by click NEXT button, for system to validated data.

Fund Request Advancement - Submission

1 Navigation on each page, will show a page status. If the page is grey, the page is new without any record saved or created.

2 If the page is orange, the page has saved some draft data. This data has been created by, but is not a complete set of data. Which means, the data has not pass the system business validation.

3 If the page is green, the page has been completed, and system has validated the data

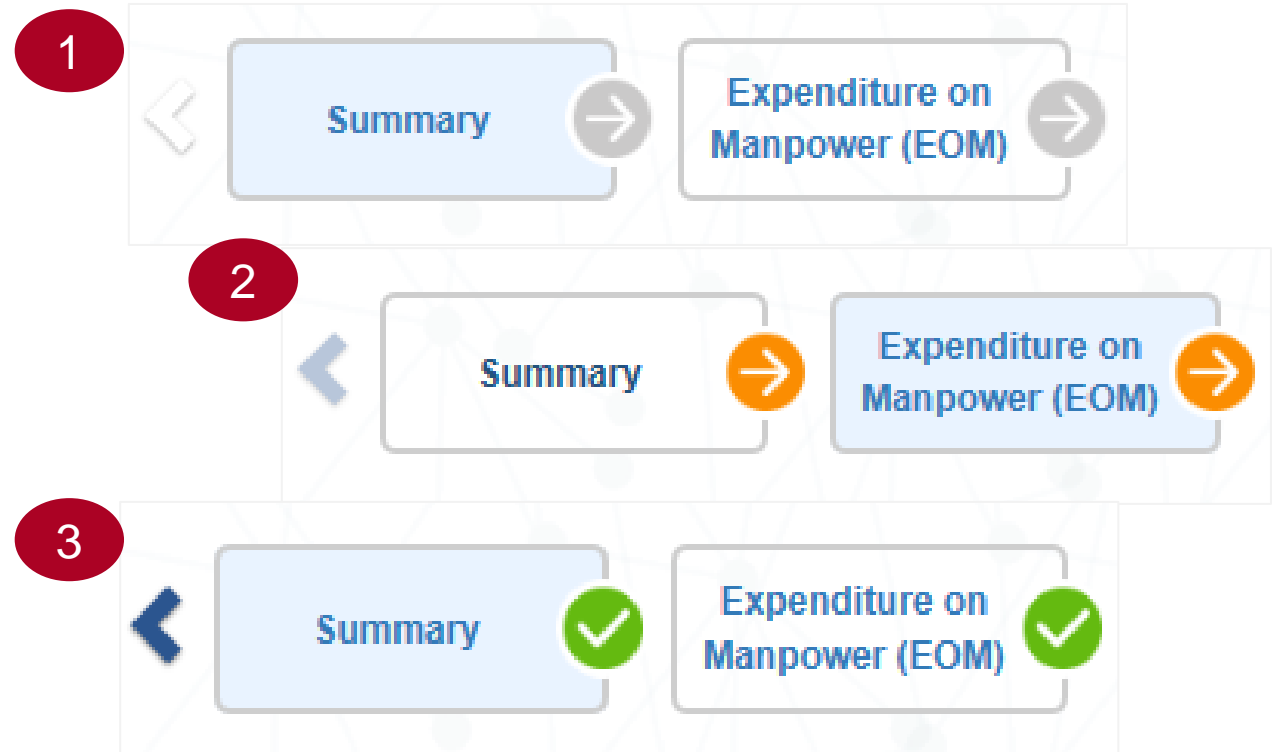

Notes:

You can only submit Fund Request if all pages mark as Green (Completed).

Fund Requisition

1. Overview and Navigation of IGMS
2. Fund Requisition (Project Claim)
 - Understanding Fund Requisition
 - Fund Requisition Type
 - Fund Requisition Period (Claim Period)
 - Fund Requisition Status
 - Fund Requisition Pages
 - Fund Requisition Navigation Bar
 - **Understanding Fund Requisition Upload Process**
 - Upload File Validation
 - Business Validation
 - Understanding Fund Requisition Approval

Fund Requisition

- Upload and Submit Fund Requisition
 - Advancement
 - Statement of Account
 - Reimbursement
 - Review and Re-upload Fund Requisition (All Methods)
 - Editing calculated IDC for RIE 2015
3. Cash Flow Projection
- Create & Submit Cash Flow Projection
 - Review Cash Flow Projection
4. Download Fund Requisition

Fund Requisition Upload Process

Fund Requisition – Upload Process

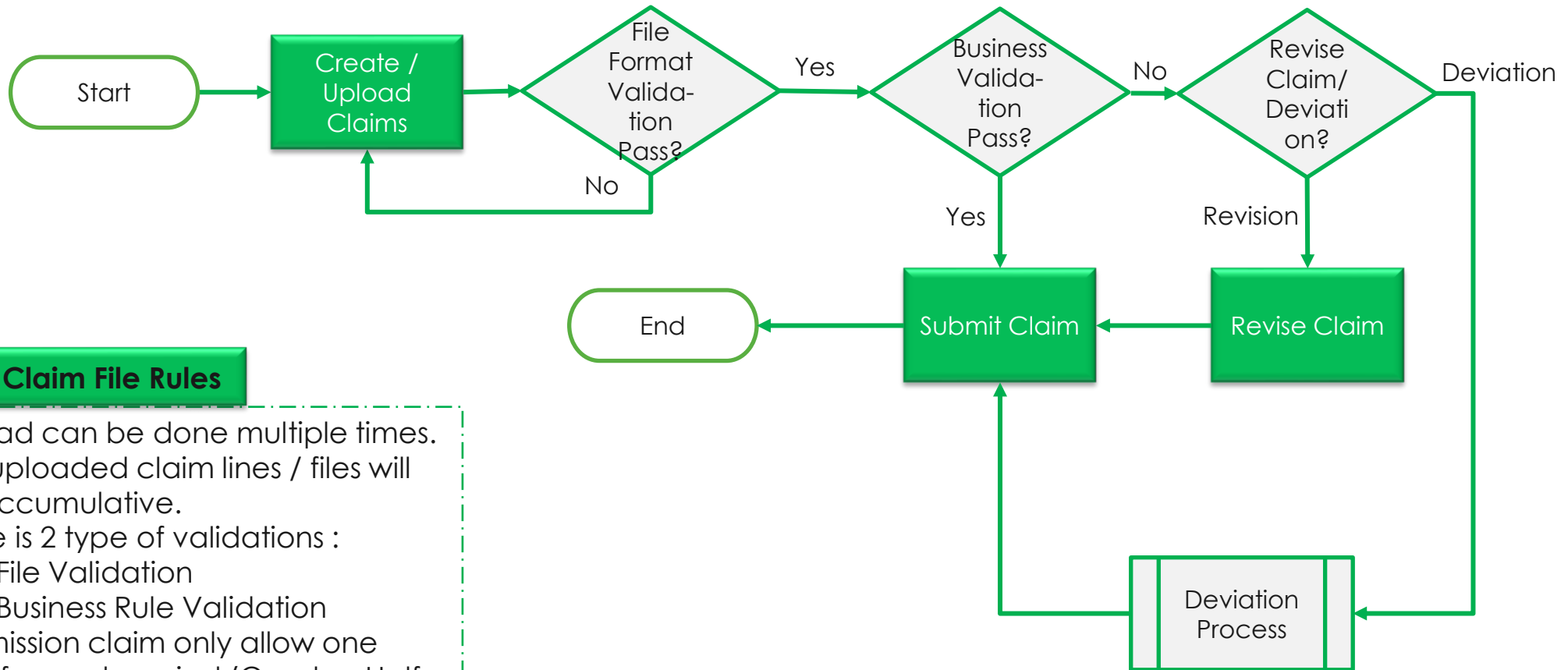

Upload Claim File Rules

1. Upload can be done multiple times. The uploaded claim lines / files will be accumulative.
2. There is 2 type of validations :
 - ✓ File Validation
 - ✓ Business Rule Validation
3. Submission claim only allow one time for each period (Quarter, Half Year, or Yearly)
4. When Claim returned for amendment, you are **not allow to upload additional claim file.**
5. IGMS only accept CSV (Comma Separated Value) file type for claim.

Upload File Validation (Parsing File)

Fund Requisition – Upload File Validation

No	Validation Type	Description/Remark
1	File type only CSV	
2	File format following template that provided by IGMS	The CSV file template can be downloaded from IGMS
3	Field Project Number	Mandatory For All Votes
4	Field Budget Category	Mandatory For All Votes
5	Field Account No.	Mandatory For All Votes
6	Field Account Description	Mandatory For All Votes
7	Field Posting Date	<ul style="list-style-type: none">• Mandatory for EOM and RS,• Only accepts Date format DD-MM-YYYY DD-MM-YY DD-MMM-YYYY DD-MMM-YY

Fund Requisition – Upload File Validation

No	Validation Type	Description/Remark
8	Field Invoice/service rendered date	<ul style="list-style-type: none"> Mandatory for OOE, EQP, OT, EI. (Except Commitment) Only accepts Date format DD-MM-YYYY DD-MM-YY DD-MMM-YYYY DD-MMM-YY
9	Field Document No.	Mandatory for all Votes.
10	Field PO No.	<ul style="list-style-type: none"> Mandatory for EQP, EI. If EQP / EI does not has PO Number, Please key in PO No same as Invoice Number
11	Field PO Date	<ul style="list-style-type: none"> Mandatory for EQP, EI. If EQP / EI No PO Number, Please key in PO Date same as Invoice/service rendered date Only accepts date format DD-MM-YYYY DD-MM-YY DD-MMM-YYYY DD-MMM-YY

Fund Requisition – Upload File Validation

No	Validation Type	Description/Remark
12	Field Vendor Name	Mandatory for EQP and EI
13	Field Item Description	Mandatory For All Votes
14	Field Amount	<ul style="list-style-type: none"> • Mandatory For All Votes • If Null (FOC items) Please put 0 • Comma in dollar value separator is accepted
15	Field Commitment (E/C)	<ul style="list-style-type: none"> • E for Expense, valid for reimbursement, advancement, SOA. • C for Commitment, valid for advancement, vote type OOE and EQP
16	Field Invoice No.	Mandatory for OOE, EQP, OT, EI (Except Commitment)
17	Field Travel Date (From)	<ul style="list-style-type: none"> • Mandatory for OT • Only accepts date format DD-MM-YYYY DD-MM-YY DD-MMM-YYYY DD-MMM-YY

Fund Requisition – Upload File Validation

No	Validation Type	Description/Remark
18	Field Travel Date (To)	<ul style="list-style-type: none">• Mandatory for OT• Only accepts date format DD-MM-YYYY DD-MM-YY DD-MMM-YYYY DD-MMM-YY
19	Ongoing FRs	<p>CSV upload from Projects → Submit claim option will fail with the following error if any of the projects mentioned in the CSV file has an ongoing FR with the workflow status Pending Resubmission or Pending HI HR Input or Pending Review or Pending PM Review.</p> <p>Error message: “CSV upload is not allowed during resubmission of an FR or if there is an FR pending approval”.</p> <p>Example:</p> <ol style="list-style-type: none">1. MOH-001525-01 has an ongoing FR with the status pending resubmission.2. User uploaded a CSV file containing claim lines for the project MOH-001525-01.3. After the claim upload batch job run, CSV upload failed with the error because the project MOH-001525-01 has an ongoing FR.

Business Validation

Fund Requisition – Business Validation

No	Validation Type	Description/Remark
1	Posting Date	<ul style="list-style-type: none"> • Posting Date Must Be After Project Start Date • Posting Date Maximum 6 Months After Project End Date. • Posting Date Maximum of 18 months After project End Date (only applicable for RS Vote type, MOE Grants tier 2). • Posting Date is Maximum of 6 months after the project end date for EOM vote type, MOE Grants tier 2).
2	Invoice/service rendered date	<ul style="list-style-type: none"> • Invoice/service rendered date Must be between and include project start – end date • Invoice/service rendered date must be after or equal as PO Date
3	PO Date	<ul style="list-style-type: none"> • PO Date Must be between and include project start – end date
4	Travel Date (From)	<ul style="list-style-type: none"> • Travel Date (From) must be after or equal as project start date • Travel Date (From) must be earlier than or equal Travel Date (To)
5	Travel Date (To)	<ul style="list-style-type: none"> • Travel Date (To) must be before or equal as project end date • Travel Date (To) must be after than or equal Travel Date (From)

Fund Requisition – Business Validation

No	Validation Type	Description/Remark
6	Amount	Claim amount must not exceed budget after <i>Latest Approved Budget Balance + Outstanding Virement Trim – Disbursed Amount</i>
7	IDC Amount	<ul style="list-style-type: none">Indirect costs amount must not exceed indirect cost budget after virement.
8	1 Fund Request Per Period	<ul style="list-style-type: none">Within one claim period (Quarterly, Half Yearly, or Yearly), only one Fund Requisition is allowed to be submitted
9	Fund Request Submission Rule	<ul style="list-style-type: none">Grantee only allow to submit Fund Request, if previous Fund Request has been approved
10	Sub Projects	<ul style="list-style-type: none">Fund Request is uploaded and submitted in sub-projects level.
11	Is there any outstanding Budget Trim?	When there is an outstanding budget trim under the same project, system will not allow FR submission

Notes:

Per-VOTE(s) e.g : latest approved budget for EQP, EOM, OOE, OT, SHC, RS, and EI
* Simulation on the next slide

Fund Requisition – Business Validation (Final Claim)

No	Validation Type	Description/Remark
1	Final Claim	<ul style="list-style-type: none">• Only one final claim is allowed to be submitted within 6 months after the project end date regardless of the quarter.• If there is already an existing Draft FR, it will be updated with the new information on the uploaded *.csv file.• If there is already a Submitted or Approved final claim, the upload of a new CSV file will not be allowed.
		<ul style="list-style-type: none">• Final claim submission should be submitted within 6 months after the project end date.• Any Draft Final claim should be submitted by the HI Finance within 6 months after the project end date.• All claims submitted after 6 months of the project end date will be blocked during the upload of the *.csv file or during the submission of the final claim.
		<ul style="list-style-type: none">• Final claims cannot be submitted for Closed projects. Claims submitted for Closed projects will be blocked during the upload of the *.csv file or during the submission of the FR.

Fund Requisition – Business Validation (Statement of Account)

No	Validation Type	Description/Remark
1	Statement of Account	<ul style="list-style-type: none"> • Only one Statement of Account is allowed to be submitted within 6 months after the project end date regardless of the quarter. • If there is already an existing Draft FR, it will be updated with the new information on the uploaded *.csv file. • If there is already a Submitted or Approved SOA, the upload of a new CSV file will not be allowed. • Any Draft SOA should be submitted by the HI Finance within 6 months after the project end date.
		<ul style="list-style-type: none"> • All SOA submitted after 6 months of the project end date will be blocked during the upload of the *.csv file or during the submission of the SOA. • SOA cannot be submitted for Closed projects. SOA submitted for Closed projects will be blocked during the upload of the *.csv file or during the submission of the FR.
2	Negative Claim	<ul style="list-style-type: none"> • If there is already an Approved Statement of Account, a negative claim is allowed to be uploaded. • Upload of Negative claim will be blocked if the SOA status is not Approved Pending Payment.

Simulation Budget Balance Checking

Simulation Budget Balance Checking - Reimbursement

Vote	Original budget (B)	Revised budget (C)	Budget balance after proposed virement and trim (D)	Cum. expense approved (E)	Quarterly claim (F)	Total expenses (G=E+F)	Budget balances (H=D-G)	Budget utilisation (I=G/C)
EOM	1,000,000.00	1,100,000.00	900,000.00	500,000.00	230,000.00	730,000.00	170,000.00	66.36
OOE	1,000,000.00	900,000.00	1,100,000.00	100,000.00	800,000.00	900,000.00	200,000.00	100.00
EQPT	500,000.00	500,000.00	500,000.00	-	400,000.00	400,000.00	100,000.00	80.00
OT	250,000.00	250,000.00	250,000.00	230,000.00	25,000.01	255,000.01	(5,000.01)	102.00
RS	-	-	-	-	-	-	-	-
SHC	-	-	-	-	-	-	-	-
EI	-	-	-	-	-	-	-	-
IDC	550,000.00	550,000.00	550,000.00	166,000.00	291,000.00	457,000.00	93,000.00	83.09
Total exc IDC	2,750,000.00	2,750,000.00	2,750,000.00	830,000.00	1,455,000.01	2,285,000.01	464,999.99	83.09
Total	3,300,000.00	3,300,000.00	3,300,000.00	996,000.00	1,746,000.01	2,742,000.01	557,999.99	83.09

* At any point of time, if any value of column H is less than zero, HI finance / HR / PI / PM / Agency Finance will not be able to submit or approve the entire Fund Requisition

Simulation Budget Balance Checking - Advancement

Vote	Original budget (B)	Revised budget (C)	Budget balance after proposed virement and trim (D)	Cum. fund receive prev Q (E)	Cum. exp. prev Q (F)	Last Q exp. (G)	Total exp. prev. Q (H=F+G)	Fund balance prev Q (I=E-H)	Commitments (J)	Project exp. current Q (K)	Amount current Q (L=J+K-I)	Budget balances (M=D-E-L)	Budget utilisation (N=(E+L)/C)
EOM	1,500,000.00	1,600,000.00	1,400,000.00	392,400.00	162,400.00	63,900.00	226,300.00	166,100.00	-	1,230,000.00	1,063,900.00	(56,300.00)	91.02
OOE	900,000.00	800,000.00	1,000,000.00	297,124.14	147,124.14	98,126.59	245,250.73	51,873.41	48.63	123,400.00	71,575.22	631,300.64	46.09
EQP	1,000,000.00	1,000,000.00	1,000,000.00	383,104.20	233,104.20	116,552.10	349,656.30	33,447.90	8,820.59	134,500.00	109,872.69	507,023.11	49.30
OT	250,000.00	250,000.00	250,000.00	53,417.54	15,917.54	7,958.77	23,876.31	29,541.23	-	2,199,900.00	2,170,358.77	(1,973,776.31)	889.51
RS	-	-	-	-	-	-	-	-	-	-	-	-	-
SHC	-	-	-	-	-	-	-	-	-	-	-	-	-
EI	-	-	-	-	-	-	-	-	-	-	-	-	-
IDC	730,000.00	730,000.00	730,000.00	225,209.18	111,709.18	57,307.49	169,016.67	56,192.51	1,773.84	737,560.00	683,141.34	(178,350.51)	124.43
Total exc IDC	3,650,000.00	3,650,000.00	3,650,000.00	1,126,045.88	558,545.88	286,537.46	845,083.34	280,962.54	8,869.22	3,687,800.00	3,415,706.68	(891,752.56)	124.43
Total	4,380,000.00	4,380,000.00	4,380,000.00	1,351,255.06	670,255.06	343,844.95	1,014,100.01	337,155.05	10,643.06	4,425,360.00	4,098,848.02	(1,070,103.07)	124.43

* At any point of time, if any value of column M is less than zero, HI finance / HR / PI / PM / Agency Finance will not be able to submit or approve the entire Fund Requisition

Simulation Budget Balance Checking - Advancement

System validates in the case of budget balance. When the Fund Balance (column I) is more than the Budget Balance after Proposed Virement and Trim (column D), the Amount required (column L) should reflect as Budget Balance after Proposed Virement and Trim (column D) minus the Fund Balance (column I). In such case, the Budget Balance (column M) should reflect as zero (0).

Impact on Fund Requests - Advancement:

Vote	Original budget (B)	Revised budget (C)	Budget balance after proposed virement and trim (D)	Cum. fund receive prev Q (E)	Cum. exp. prev Q (F)	Last Q exp. (G)	Total exp. prev. Q (H=F+G)	Fund balance prev Q (I=E-H)	Commitments (J)	Project exp. current Q (K)	Amount current Q (L=J+K-I)	Budget balances (M=D-E-L)	Budget utilisation (N=(E+L)/C)
EOM	1,500,000.00	1,600,000.00	1,400,000.00	392,400.00	162,400.00	63,900.00	226,300.00	166,100.00	-	1,230,000.00	1,063,900.00	(56,300.00)	91.02
OOE	900,000.00	800,000.00	1,000,000.00	297,124.14	147,124.14	98,126.59	245,250.73	51,873.41	48.63	123,400.00	71,575.22	631,300.64	46.09
EQP	1,000,000.00	1,000,000.00	100,000.00	383,104.20	233,104.20	15,000.00	248,104.20	135,000.00	8,820.59	134,500.00	(35,000.00)	0.00	34.81
OT	250,000.00	250,000.00	250,000.00	53,417.54	15,917.54	7,958.77	23,876.31	29,541.23	-	2,199,900.00	2,170,358.77	(1,973,776.31)	889.51
RS	-	-	-	-	-	-	-	-	-	-	-	-	-
SHC	-	-	-	-	-	-	-	-	-	-	-	-	-
EI	-	-	-	-	-	-	-	-	-	-	-	-	-
IDC	730,000.00	730,000.00	550,000.00	225,209.18	111,709.18	36,997.07	148,706.25	76,502.93	1,773.84	737,560.00	654,166.80	(279,755.13)	120.46
Total exc IDC	3,650,000.00	3,650,000.00	2,750,000.00	1,126,045.88	558,545.88	184,985.36	743,531.24	382,514.64	8,869.22	3,687,800.00	3,270,833.99	(1,398,775.67)	120.46
Total	4,380,000.00	4,380,000.00	3,300,000.00	1,351,255.06	670,255.06	221,982.43	892,237.49	459,017.57	10,643.06	4,425,360.00	3,925,000.79	(1,678,530.80)	120.46

* At any point of time, if any value of column M is less than zero, HI finance / HR / PI / PM / Agency Finance will not be able to submit or approve the entire Fund Requisition

Simulation Budget Balance Checking - SoA

Fund Request Statement of Account (For Advancement Mode)

Vote (A)	Approved budget (B)	Total grant received (C)	Cum exp per period (D)	Current expense (E)	Total expenses (F)	Disburse amount (G = C-F)	Budget utilisation (H = F/B)
EOM	400,000.00	240,989.70	330,989.70	78,000.00	408,989.70	(168,000.00)	57.77%
OOE	400,000.00	150,908.16	136,172.16	114,500.00	250,672.16	(99,764.00)	62.67%
EQP	400,000.00	68,800.40	35,798.40	111,505.00	147,303.40	(78,503.00)	36.83%
OT	400,000.00	234,812.00	224,812.00	111,167.00	335,979.00	(101,167.00)	83.99%
RS	400,000.00	232,222.00	222,222.00	-	222,222.00	10,000.00	55.56%

* At any point of time, if any value on column F exceed latest approved budget, HI Finance not able to submit Statement of Account (Advancement Mode)

Fund Requisition

1. Overview and Navigation of IGMS
2. Fund Requisition (Project Claim)
 - Understanding Fund Requisition
 - Fund Requisition Type
 - Fund Requisition Period (Claim Period)
 - Fund Requisition Status
 - Fund Requisition Pages
 - Fund Requisition Navigation Bar
 - Understanding Fund Requisition Upload Process
 - Upload File Validation
 - Business Validation
 - **Understanding Fund Requisition Approval**

Fund Requisition

- Upload and Submit Fund Requisition
 - Advancement
 - Statement of Account
 - Reimbursement
- Review and Re-upload Fund Requisition (All Methods)
- Editing calculated IDC for RIE 2015

3. Cash Flow Projection

- Create & Submit Cash Flow Projection
- Review Cash Flow Projection

Fund Requisition Workflow Approval

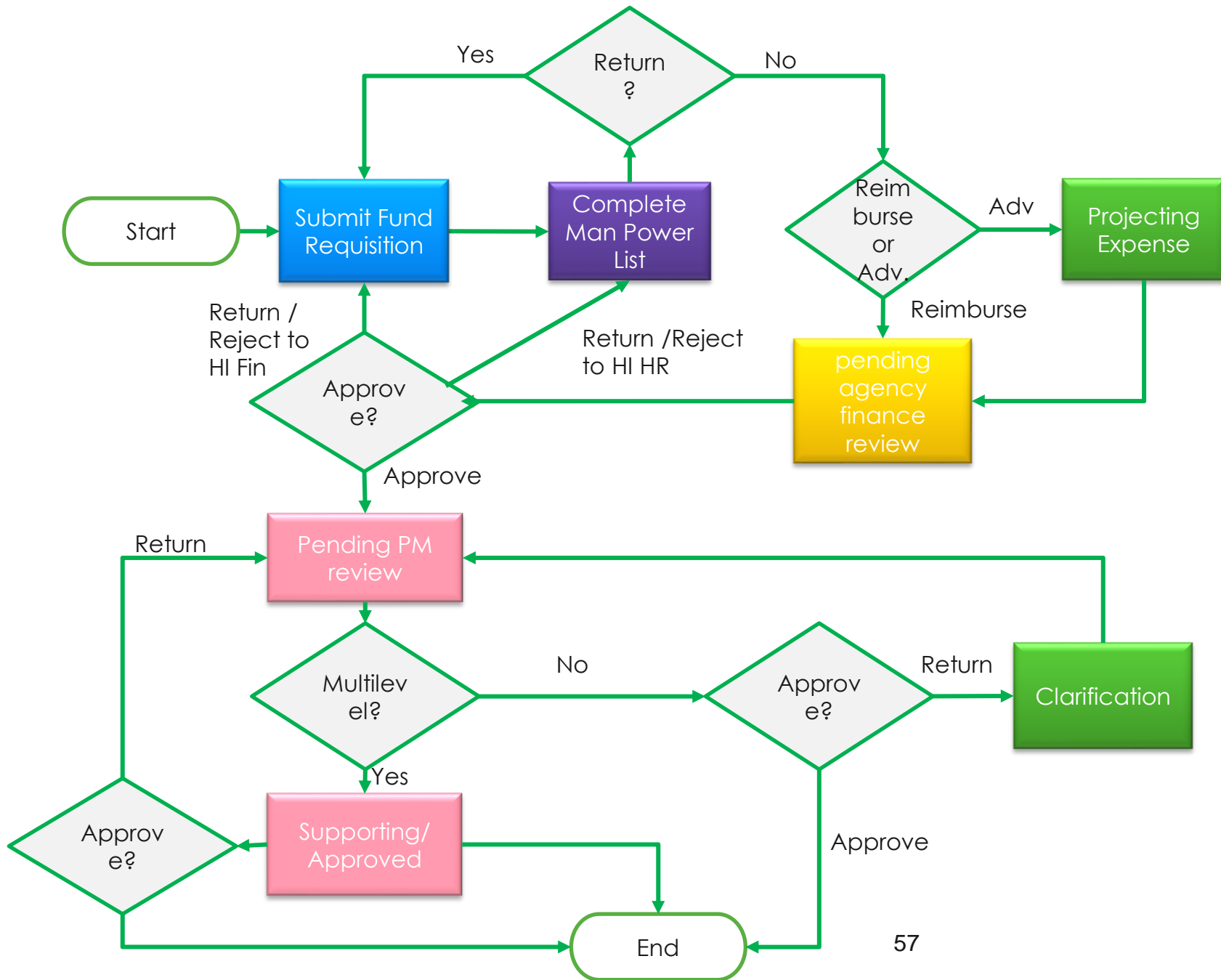

- Action by HI Finance
- Action by HI HR
- Action by PI
- Action by Agency Finance
- Action by PM / Multilevel PM

Notes :

Please ensure that there is at least one active HI Finance in the Institution at all times, to avoid disruptions to workflow.

Workflow for FRs interfaced to NRF Finance System

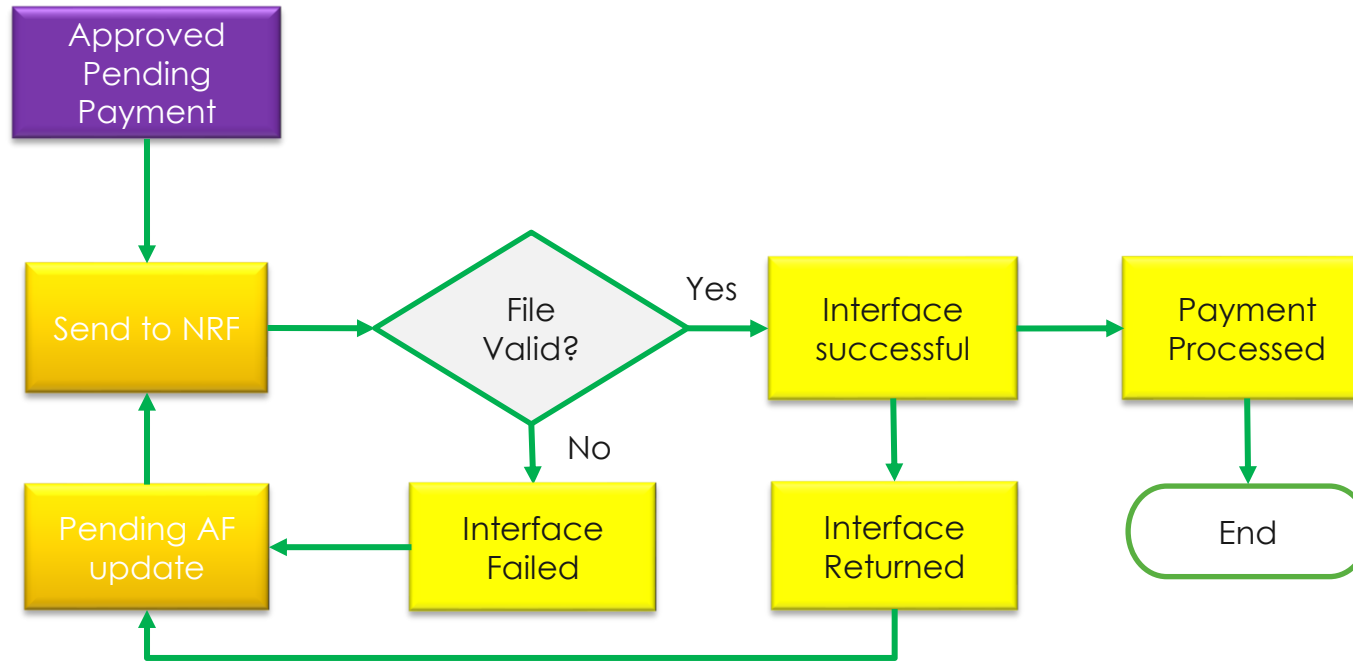

Notes :

Applicable to NRF funded projects only

Fund Requisition

1. Overview and Navigation of IGMS
2. Fund Requisition (Project Claim)
 - Understanding Fund Requisition
 - Fund Requisition Type
 - Fund Requisition Period (Claim Period)
 - Fund Requisition Status
 - Fund Requisition Pages
 - Fund Requisition Navigation Bar
 - Understanding Fund Requisition Upload Process
 - Upload File Validation
 - Business Validation
 - Understanding Fund Requisition Approval

Fund Requisition

- **Upload and Submit Fund Requisition**

- Advancement
- Statement of Account
- Reimbursement

- Review and Re-upload Fund Requisition (All Methods)
- Editing calculated IDC for RIE 2015

3. Cash Flow Projection

- Create & Submit Cash Flow Projection
- Review Cash Flow Projection

4. Download Fund Requisition

Fund Requisition Advancement - Upload and Submission Process

Fund Request Advancement

Claim method Advancement:

- If you applied for grant call under managing agency A*STAR, all claim method is advance payment.

Keynotes:

- In the beginning of each period (quarterly/half yearly/yearly) you will receive email to submit a claim from previous period.
- Definition advancement : expenditure incurred in the previous quarter/Year/Half year, using the funds received and the funds required in the current quarter/Year/Half yearly, and the occurred expenses in quarter/Year/Half yearly, adding by projected expense and commitment PO (EQP and OOE), The system then computes the net amount required for advancement amount.
- If calculation of net amount reach negative value, system will omit it as a zero, so Grantee does not need to refund on each quarter.
- Unless, if there is any virement or for related project, then once the calculation of net amount reach negative, Grantee need to refund to Agency.

Fund Requisition – Create or Upload Claim (Adv)

1 Click on *Projects > View Projects* to view Fund Requisition(s) submitted of respective Award/Project Refer to the Project Tracking Training Material for more details

2 Click on *Projects > Submit Claim* to create / upload a new Fund Requisition

3 Click on *Projects > View Claim Upload History* to check the status of Fund Requisition uploaded

4 Click on *Projects > Submit Cashflow Projection* to submit a cash flow projection.

The screenshot shows the NCS PST's HI Finances 1 (HI Finan...) dashboard. The top navigation bar includes 'Dashboard', 'Projects', 'Deviations', and 'Advanced Search'. The 'Projects' dropdown menu is open, showing options: 'View Projects', 'Submit Claim', 'View Claim Upload History', and 'Submit Cashflow Projection'. Red circles with numbers 1, 2, 3, and 4 are placed over these menu items. Below the menu, there is a section titled 'Upload Claim' with a button and a message '1 - 10 of 470 matching results found'. A table displays the list of projects eligible to claim for the current period.

S/N	Project no.	Latest upload date	HI claim no.	Upload status	Fund Request status	Error details
1	ASTR-000064-01	14-May-2019	TST140519-03	Completed	None	
2	ASTR-000071-01			Pending	None	
3	ASTR-000072-01			Pending	None	
4	ASTR-000074-01			Pending	None	

Notes :

Cash Flow Projection is not mandatory for each Host Institution. HI can submit Cash flow projection if it is required.

Fund Requisition – Create or Upload Claim (Adv)

1 In submit claim page, we have two sub-sections as follows. "Upload claim" button is used for CSV claim file uploading.

2 Project no column will display the list of sub-projects hyperlink.

3 Last upload date is the last date for the csv claim file uploaded.

4 HI Claim No, is number specified by Grantee to identify the claim number for each submission

Home > Projects > Submit Claim

Claim submission

Project Running for Current Quarter

These are the list of projects that are eligible to claim for the current period.

[Upload Claim](#) 1

1 - 10 of 83 matching results found

5 6 7

S/N	Project no. 2	Latest upload date 3	HI claim no. 4	Upload status 5	Fund Request status 6	Error details 7
1	ASTR-000002-02			Pending	None	
2	ASTR-000003-01			Pending	None	
3	ASTR-000004-01			Pending	None	
4	ASTR-000005-01			Pending	None	
5	ASTR-000006-01			Pending	None	
6	ASTR-000012-01			Pending	None	
7	ASTR-000024-01			Pending	None	
8	ASTR-000026-01			Pending	None	
9	ASTR-000031-01			Pending	None	
10	ASTR-000032-01			Pending	None	

Fund Requisition – Create or Upload Claim (Adv)

1 Claim submission page will display after click on “upload claim” in submit claim page

To download a CSV claim template, click the link to download.

2 HI claim number is mandatory for Grantee to specify a submission unique number.

3 To upload file, click attach files.

4 Click submit button.

The screenshot shows the 'HI claim submission' interface. At the top, there's a blue header with 'HI claim submission'. Below it, a section titled 'Hide Claim Details' shows the 'HI claim submission no' as 'f5017bab-5f46-4af7-9061-b503ee24e726', the 'Status' as 'Draft', and the 'Submission date and time' field. A blue bar labeled 'HI claims upload' contains instructions: 'Please click here to download template. To upload the claim, click the 'Attach files...' button. Once completed, click the 'Start upload' button. File types allowable: csv only. The maximum size for each file is 4 MB.' Below this, a note states: '"Project ID" is mandatory. Please key in the "Project ID" for the claim submission'. A link 'Click here to download csv template.' is provided. The 'HI claim no' field is empty and has a red circle '2' next to it. A red circle '1' is next to the 'Project ID' note. A red circle '3' is next to the '+ Attach files...' button. A red circle '4' is next to the 'Submit' button at the bottom right. A pink note box says: 'NOTE: The attached file(s) if any will be displayed after anti-virus scan is completed. Please wait and visit this page later.'

Understanding of Claim Submission page (Adv)

5 After click on “submit “ button ,one dialogue box will display as follows “**File has been uploaded. An email notification will be sent shortly**”. Then click on “**OK**” button.

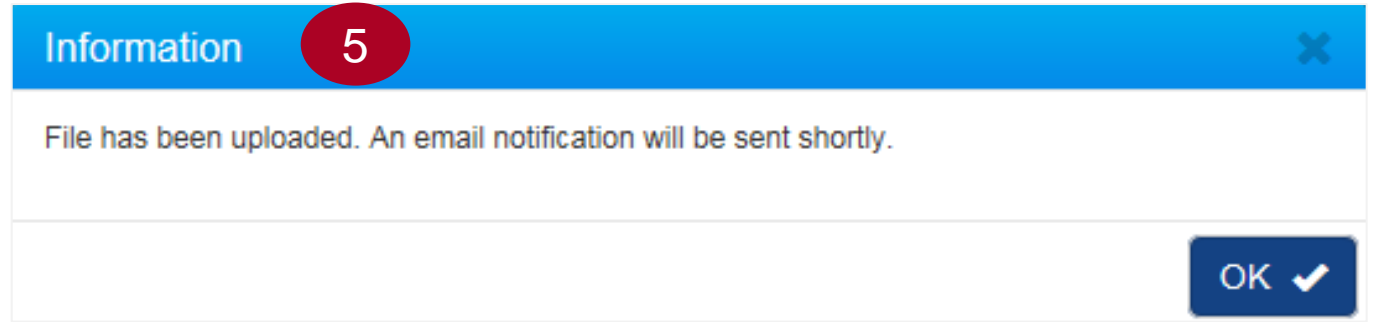

Notes:

- Multiple files can be uploaded simultaneously.
- Multiple projects can be grouped within one file.
- After uploaded, IGMS running a parsing file process.
- Once parsing process completed, HI Finance will receive notification either to submit (if successfully uploaded).
- Or, to revise and re-upload. (if file format validation is fail).
- This is for new Fund Requisition submissions only.
- For Fund Requisitions that have already been submitted and rejected, reupload the file under "Re-upload requisition details" (page 148).

Understanding View Claim Upload History (Adv)

1 Claim upload history is a page to navigated the parsing process of uploaded claim/s. With this page, HI Finance can track the history of uploaded claim.
 HI Claim Submission No, is unique ID generated by IGMS each time claim is uploaded. This ID is unique according uploaded batch.

2 HI Claim No, is ID specified by Grantee to identified each time submission.

3 No of uploaded records, is number of claim line uploaded

View Claim Upload History

Upload History

The purpose of this page is to allow users to navigate the history of uploaded claims. Upload status include: In Progress, Completed and Failed. To obtain the details for the failed upload, please click on the error file.

Upload Claim

1 - 10 of 95 matching results found

S/N	HI claim submission no.	HI claim no	No of uploaded records	No of failed records	Submitted date & time	Upload status	Uploaded By	Error details
1	1f9ac8a9-b608-49a6-b018-5ec27b98e527	Sept 2018	0	399	09-05-2018 14:55:29	Failed	P93	Click here to download errors.
2	f5017bab-5f46-4af7-9061-b503ee24e726	Jun-Sept 2018-001	0	399	09-05-2018 14:33:35	Failed	ORE91	Click here to download errors.
3	27f95d8a-4647-40fe-9752-64dda08099f3	HI claim no 880	35	0	08-05-2018 14:48:03	Completed	OR5	
4	d40a5974-738c-4955-9d1c-fec05eb410ce	test	16	0	07-05-2018 17:01:30	Completed	p96	
5	68576ef1-e15f-485b-930f-d7f10ffbc265	142	0	399	07-05-2018 14:15:18	Failed	ORE91	Click here to download errors.
6	7cde8d2d-8941-4213-b38a-ae99d3700b94	2 testing	10	0	07-05-2018 14:11:29	Completed	P93	
7	afe60c7f-518d-4f84-b8a8-b642f1081403	test	16	0	07-05-2018 14:03:58	Completed	p96	

Verify Parsing File Result (Advancement)

Understanding View Claim Upload History (Adv)

4 No failed records, is number of failed records to upload.

5 Submitted date and time, are date and time when the file has been uploaded

6 Upload Statuses are :

- Failed, file parsing process failed
- Completed, file parsing process completed

7 Uploaded by, is HI Finance user name that uploading the file.

View Claim Upload History

Upload History

The purpose of this page is to allow users to navigate the history of uploaded claims. Upload status include: In Progress, Completed and Failed. To obtain the details for the failed upload, please click on the error file.

Upload Claim

1 - 10 of 95 matching results found

5 6 1 7 4 5 8

S/N	HI claim submission no.	HI claim no.	No of uploaded records	No of failed records	Submitted date & time	Upload status	Uploaded By	Error details
1	1f9ac8a9-b608-49a6-b018-5ec27b98e527	Sept 2018	0	399	09-05-2018 14:55:29	Failed	P93	Click here to download errors.
2	f5017bab-5f46-4af7-9061-b503ee24e726	Jun-Sept 2018-001	0	399	09-05-2018 14:33:35	Failed	ORE91	Click here to download errors.
3	27f95d8a-4647-40fe-9752-64dda08099f3	HI claim no 880	35					
4	d40a5974-738c-4955-9d1c-fec05eb410ce	test	16					
5	68576ef1-e15f-485b-930f-d7f10ffb265	142	0					
6	7cde8d2d-8941-4213-b38a-ae99d3700b94	2 testing	10					
7	afe60c7f-518d-4f84-b8a8-b642f1081403	test	16					

Notes :

IGMS will reject the whole claim file, if uploaded file/files does not meet the file validation criteria (slide 37 to 40).

Understanding View Claim Upload History (Adv)

8 Error file. Error file use to tracking the reason why the file is failed for validation.

View Claim Upload History

Upload History

The purpose of this page is to allow users to navigate the history of uploaded claims. Upload status include: In Progress, Completed and Failed. To obtain the details for the failed upload, please click on the error file.

Upload Claim

1 - 10 of 95 matching results found

5 K 6 1 7 4 5 > 8

S/N	HI claim submission no. 1	HI claim no. 2	No of uploaded records 3	No of failed records 4	Submitted date & time	Upload status	Uploaded By	Error details
1	1f9ac8a9-b608-49a6-b018-5ec27b98e527	Sept 2018	0	399	09-05-2018 14:55:29	Failed	P93	Click here to download errors.
2	f5017bab-5f48-4af7-9061-b503ee24e726	Jun-Sept 2018-001	0	399	09-05-2018 14:33:35	Failed	ORE91	Click here to download errors.
3	27f95d8a-4647-40fe-9752-64dda08099f3	HI claim no 880	35					
4	d40a5974-738c-4955-9d1c-fec05eb410ce	test	16					
5	68576ef1-e15f-485b-930f-d7f10fbc265	142	0					
6	7cde8d2d-8941-4213-b38a-ae99d3700b94	2 testing	10					
7	afe80c7f-518d-4f84-b8a8-b642f1081403	test	16					

Notes :

IGMS will reject the whole claim file, if uploaded file/files does not meet the file validation criteria (slide 37 to 42)

Understanding View Claim Upload History (Adv)

9

Once HI Finance click hyperlink to download the error file, IGMS will provide the details why uploaded file has error.

Line No, is the claim line number that causing an error/s

Error details is the invalid field value. Either because the data keyed in on the field is a wrong format, or if a mandatory information on each VOTES is missing.
(Details on slide 37-40)

Line No.	Error Details
15	Budget Category is empty
110	Posting Date is mandatory for EOM and RS
114	Account No is empty.Account Description is empty.Document No is empty.Item Description is empty.Amount is empty
118	Project Id is empty
171	Account No is empty.Account Description is empty.Document No is empty.Item Description is empty.Amount is empty
231	Account No is empty.Account Description is empty.Document No is empty.Item Description is empty.Amount is empty
247	Account No is empty.Account Description is empty.Document No is empty.Item Description is empty.Amount is empty
263	Document No is empty.PO Date is mandatory for EQP and EI.Vendor name is mandatory for EQP and EI
396	Account No is empty.Account Description is empty.Document No is empty.Item Description is empty.Amount is empty
397	Overseas Travel Date is mandatory for OT
398	Invoice No is mandatory for OOE or EQP or OT or EI.Invoice Date is mandatory for OOE or EQP or OT or EI.Overseas Travel Date

9

Fund Requisition Summary Page (Advancement)

Fund Requisition Summary Page (Advancement)

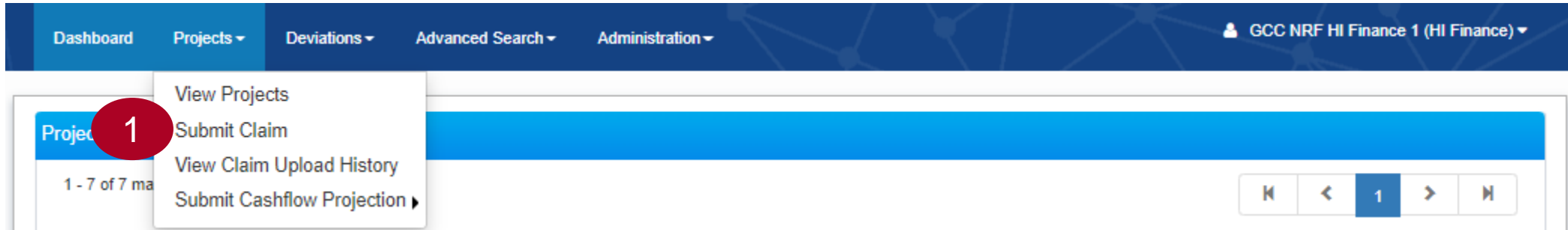

1 Once the Upload Status is "Completed", navigate to Projects > Submit Claim, to view the list of projects for which a claim can be submitted.

2 Browse the list to find the FR record. Project Number indicates the Project ID and HI Claim No. displays the value entered by the user during claim upload.

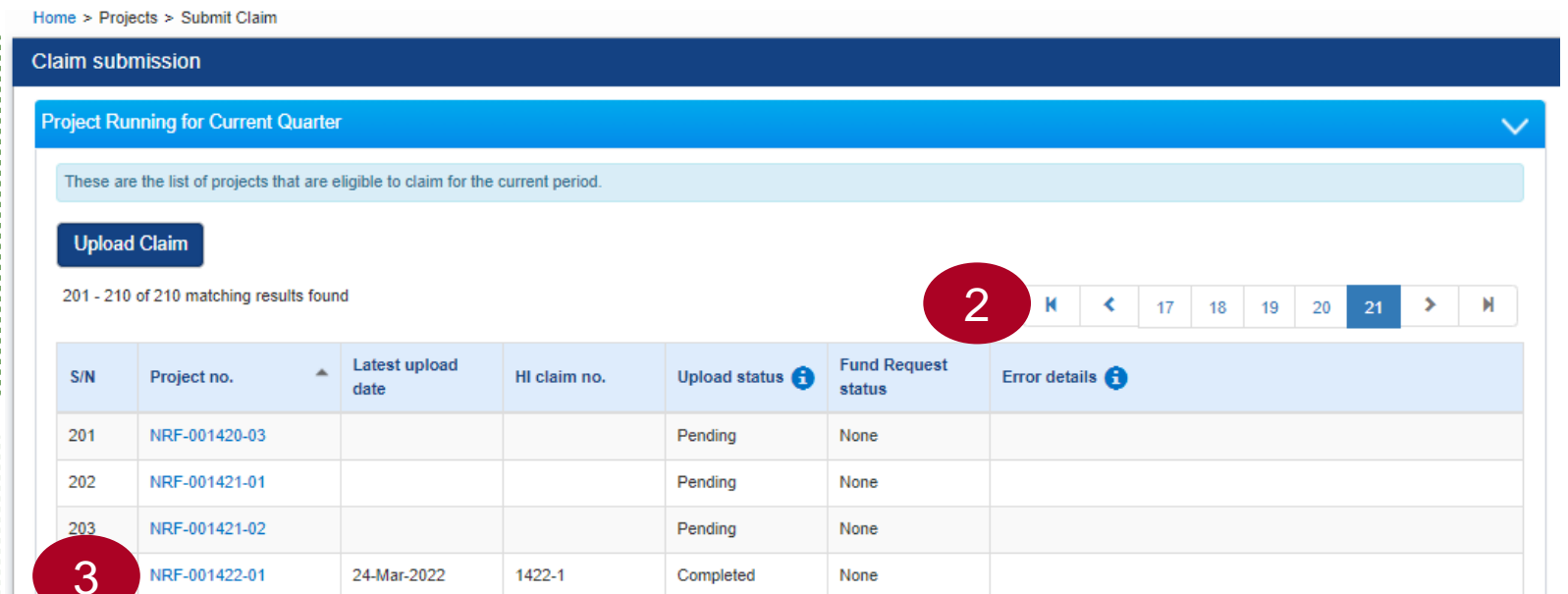

3 Click on the "Project no." hyperlink to access the FR to complete the submission.

Fund Requisition Summary Page (Advancement)

1 For advancement method, after claim uploaded, the amount will be populated in a summary page :

1. Vote is budget group / category that available for related project. Overall available VOTES are :

- Expenditure of Manpower (EOM)
- Other Operating Expenditure (OOE)
- Equipment (EQP)
- Overseas Travel (OT)
- Research Scholarship (RS)
- Exceptional Item (EI)
- Supplemental Human Capital (SHC)

Summary

VOTE	Original budget (B)	Revised budget (C)	Budget Balance After Proposed Virement and Trim (D)	Cumul fund received/ pending receipt up to 30-Jun-2019(E)	Cumul exp. up to 31-Mar-2019 (F)	Exp. Incurred in the period ended 30-Jun-2019(G)	Total exp. incurred up to 30-Jun-2019 (H=F+G)
Expenditure on Manpower (EOM)	150,000.00	150,000.00	120,000.00	21,000.00	20,000.00	0.00	20,000.00
Other Operating Expenditure (OOE)	150,000.00	150,000.00	150,000.00	12,500.00	10,000.00	0.00	10,000.00
Equipment (EQP)	150,000.00	150,000.00	180,000.00	11,250.00	10,000.00	0.00	10,000.00
Overseas Travel (OT)	150,000.00	150,000.00	150,000.00	0.00	0.00	0.00	0.00
Research Scholarship (RS)	150,000.00	150,000.00	150,000.00	0.00	0.00	0.00	0.00
Indirect Cost (IDC)	150,000.00	150,000.00	150,000.00	14,000.00	10,000.00	0.00	10,000.00
Total	900,000.00	900,000.00	900,000.00	58,750.00	50,000.00	0.00	50,000.00

Expenditure

VOTE	Fund balance as at 30-Jun-2019(I=E-H)	Commitments (supported by POs) (J)	Projected exp. for current quarter (K)	Amount required for current quarter (L=J+K-I)	Budget balances (M=D-E-L)	Budget utilisation N= ((E+L)/C)100
Expenditure on Manpower (EOM)	1,000.00	0.00	<input type="text" value="0"/>	0.00	99,000.00	14.00%
Other Operating Expenditure (OOE)	2,500.00	0.00	<input type="text" value="0"/>	0.00	137,500.00	8.33%
Equipment (EQP)	1,250.00	0.00	<input type="text" value="0"/>	0.00	168,750.00	7.50%
Overseas Travel (OT)	0.00	0.00	<input type="text" value="0"/>	0.00	150,000.00	0.00%
Research Scholarship (RS)	0.00	0.00	<input type="text" value="0"/>	0.00	150,000.00	0.00%
Indirect Cost (IDC)	4,000.00	0.00	0.00	0.00	136,000.00	9.33%
Total	8,750.00	0.00	0.00	0.00	841,250.00	6.53%

Fund Requisition Summary Page (Advancement)

2 Project cost funded before virement, is the initial budget (original budget available)

3 Project cost funded after virement, is the available budget after virement or trim budget.

4 Project budget by taking outstanding virement/trim/SHC into consideration (column C +/- outstanding Virement/Trim).

5 Cumulative fund receive up to (previous period), is the advancement amount that has received by grantee up to previous quarter.

6 Cumulative expense up to (previous 2 quarters)

Summary

VOTE	Original budget (B)	Revised budget (C)	Budget Balance After Proposed Virement and Trim (D)	Cumul fund received/ pending receipt up to 30-Jun-2019(E)	Cumul exp. up to 31-Mar-2019 (F)	Exp. Incurred in the period ended 30-Jun-2019(G)	Total exp. incurred up to 30-Jun-2019 (H=F+G)
Expenditure on Manpower (EOM)	150,000.00	150,000.00	120,000.00	21,000.00	20,000.00	0.00	20,000.00
Other Operating Expenditure (OOE)	150,000.00	150,000.00	150,000.00	12,500.00	10,000.00	0.00	10,000.00
Equipment (EQP)	150,000.00	150,000.00	180,000.00	11,250.00	10,000.00	0.00	10,000.00
Overseas Travel (OT)	150,000.00	150,000.00	150,000.00	0.00	0.00	0.00	0.00
Research Scholarship (RS)	150,000.00	150,000.00	150,000.00	0.00	0.00	0.00	0.00
Indirect Cost (IDC)	150,000.00	150,000.00	150,000.00	14,000.00	10,000.00	0.00	10,000.00
Total	900,000.00	900,000.00	900,000.00	58,750.00	50,000.00	0.00	50,000.00

Expenditure

VOTE	Fund balance as at 30-Jun-2019(I=E-H)	Commitments (supported by POs) (J)	Projected exp. for current quarter (K)	Amount required for current quarter (L=J+K-I)	Budget balances (M=D-E-L)	Budget utilisation N= ((E+L)/C)100
Expenditure on Manpower (EOM)	1,000.00	0.00	<input type="text" value="0"/>	0.00	99,000.00	14.00%
Other Operating Expenditure (OOE)	2,500.00	0.00	<input type="text" value="0"/>	0.00	137,500.00	8.33%
Equipment (EQP)	1,250.00	0.00	<input type="text" value="0"/>	0.00	168,750.00	7.50%
Overseas Travel (OT)	0.00	0.00	<input type="text" value="0"/>	0.00	150,000.00	0.00%
Research Scholarship (RS)	0.00	0.00	<input type="text" value="0"/>	0.00	150,000.00	0.00%
Indirect Cost (IDC)	4,000.00	0.00	0.00	0.00	136,000.00	9.33%
Total	8,750.00	0.00	0.00	0.00	841,250.00	6.53%

Fund Requisition Summary Page (Advancement)

7 The current quarter expenses amount submitted by Grantee.

8 Total expense incurred up to (previous quarter).

9 Fund Balance, is calculation of cumulative amount received, deducted by expense amount.

10 Commitments, is committed expense that has not invoiced yet, only applicable for OOE and EQP.

11 Projected expenses, is the estimation of expenses will be occurred in current quarter.

Summary							
VOTE	Original budget (B)	Revised budget (C)	Budget Balance After Proposed Virement and Trim (D)	Cumul fund received/ pending receipt up to 30-Jun-2019(E)	Cumul exp. up to 31-Mar-2019 (F)	Exp. Incurred in the period ended 30-Jun-2019(G)	Total exp. incurred up to 30-Jun-2019 (H=F+G)
Expenditure on Manpower (EOM)	150,000.00	150,000.00	120,000.00	21,000.00	20,000.00	0.00	20,000.00
Other Operating Expenditure (OOE)	150,000.00	150,000.00	150,000.00	12,500.00	10,000.00	0.00	10,000.00
Equipment (EQP)	150,000.00	150,000.00	180,000.00	11,250.00	10,000.00	0.00	10,000.00
Overseas Travel (OT)	150,000.00	150,000.00	150,000.00	0.00	0.00	0.00	0.00
Research Scholarship (RS)	150,000.00	150,000.00	150,000.00	0.00	0.00	0.00	0.00
Indirect Cost (IDC)	150,000.00	150,000.00	150,000.00	14,000.00	10,000.00	0.00	10,000.00
Total	900,000.00	900,000.00	900,000.00	58,750.00	50,000.00	0.00	50,000.00

Expenditure						
VOTE	Fund balance as at 30-Jun-2019(I=E-H)	Commitments (supported by POs) (J)	Projected exp. for current quarter (K)	Amount required for current quarter (L=J+K-I)	Budget balances (M=D-E-L)	Budget utilisation N= ((E+L)/C)100
Expenditure on Manpower (EOM)	1,000.00	0.00	<input type="text" value="0"/>	0.00	99,000.00	14.00%
Other Operating Expenditure (OOE)	2,500.00	0.00	<input type="text" value="0"/>	0.00	137,500.00	8.33%
Equipment (EQP)	1,250.00	0.00	<input type="text" value="0"/>	0.00	168,750.00	7.50%
Overseas Travel (OT)	0.00	0.00	<input type="text" value="0"/>	0.00	150,000.00	0.00%
Research Scholarship (RS)	0.00	0.00	<input type="text" value="0"/>	0.00	150,000.00	0.00%
Indirect Cost (IDC)	4,000.00	0.00	0.00	0.00	136,000.00	9.33%
Total	8,750.00	0.00	0.00	0.00	841,250.00	6.53%

Fund Requisition Summary Page (Advancement)

Amount required for current quarter, is system computed required / advance amount. This amount to be pay out to grantee for advancement.

12

Budget balance, is the remaining budget, after deducted with requested amount

13

Budget utilization, is utilization percentage from the total cumulative advance amount, compared to budget after virement.

14

Summary							
VOTE	Original budget (B)	Revised budget (C)	Budget Balance After Proposed Virement and Trim (D)	Cumul fund received/ pending receipt up to 30-Jun-2019(E)	Cumul exp. up to 31-Mar-2019 (F)	Exp. Incurred in the period ended 30-Jun-2019(G)	Total exp. Incurred up to 30-Jun-2019 (H=F+G)
Expenditure on Manpower (EOM)	150,000.00	150,000.00	120,000.00	21,000.00	20,000.00	0.00	20,000.00
Other Operating Expenditure (OOE)	150,000.00	150,000.00	150,000.00	12,500.00	10,000.00	0.00	10,000.00
Equipment (EQP)	150,000.00	150,000.00	180,000.00	11,250.00	10,000.00	0.00	10,000.00
Overseas Travel (OT)	150,000.00	150,000.00	150,000.00	0.00	0.00	0.00	0.00
Research Scholarship (RS)	150,000.00	150,000.00	150,000.00	0.00	0.00	0.00	0.00
Indirect Cost (IDC)	150,000.00	150,000.00	150,000.00	14,000.00	10,000.00	0.00	10,000.00
Total	900,000.00	900,000.00	900,000.00	58,750.00	50,000.00	0.00	50,000.00

Expenditure						
VOTE	Fund balance as at 30-Jun-2019(I=E-H)	Commitments (supported by POs) (J)	Projected exp. for current quarter (K)	Amount required for current quarter (L=J+K-I)	Budget balances (M=D-E-L)	Budget utilisation N= ((E+L)/C)100
Expenditure on Manpower (EOM)	1,000.00	0.00	<input type="text" value="0"/>	0.00	99,000.00	14.00%
Other Operating Expenditure (OOE)	2,500.00	0.00	<input type="text" value="0"/>	0.00	137,500.00	8.33%
Equipment (EQP)	1,250.00	0.00	<input type="text" value="0"/>	0.00	168,750.00	7.50%
Overseas Travel (OT)	0.00	0.00	<input type="text" value="0"/>	0.00	150,000.00	0.00%
Research Scholarship (RS)	0.00	0.00	<input type="text" value="0"/>	0.00	150,000.00	0.00%
Indirect Cost (IDC)	4,000.00	0.00	0.00	0.00	136,000.00	9.33%
Total	8,750.00	0.00	0.00	0.00	841,250.00	6.53%

Fund Requisition Summary Page (Advancement)

Notes :

- When column L is less than zero, Grantee will disburse back the amount to Agency.
- This exception below will be applied if there is any trim or virement for the related VOTE that results in column I calculation in column $I < E$ AND column $I > D$; system will calculate column $L = D - I$. As such, the Budget Balance (column M) will be displayed as 0.

VOTE	Original budget (B)	Revised budget (C)	Budget Balance After Proposed Virement and Trim (D)	Cumul fund received/ pending receipt up to 30-Jun-2019(E)	Cumul exp. up to 31-Mar-2019 (F)	Exp. Incurred in the period ended 30-Jun-2019(G)	Total exp. incurred up to 30-Jun-2019 (H=F+G)
Expenditure on Manpower (EOM)	150,000.00	150,000.00	120,000.00	21,000.00	20,000.00	0.00	20,000.00
Other Operating Expenditure (OOE)	150,000.00	150,000.00	150,000.00	12,500.00	10,000.00	0.00	10,000.00
Equipment (EQP)	150,000.00	150,000.00	180,000.00	11,250.00	10,000.00	0.00	10,000.00
Overseas Travel (OT)	150,000.00	150,000.00	150,000.00	0.00	0.00	0.00	0.00
Research Scholarship (RS)	150,000.00	150,000.00	150,000.00	0.00	0.00	0.00	0.00
Indirect Cost (IDC)	150,000.00	150,000.00	150,000.00	14,000.00	10,000.00	0.00	10,000.00
Total	900,000.00	900,000.00	900,000.00	58,750.00	50,000.00	0.00	50,000.00

VOTE	Fund balance as at 30-Jun-2019(I=E-H)	Commitments (supported by POs) (J)	Projected exp. for current quarter (K)	Amount required for current quarter (L=J+K-I)	Budget balances (M=D-E-L)	Budget utilisation N= ((E+L)/C)100
Expenditure on Manpower (EOM)	1,000.00	0.00	<input type="text" value="0"/>	0.00	99,000.00	14.00%
Other Operating Expenditure (OOE)	2,500.00	0.00	<input type="text" value="0"/>	0.00	137,500.00	8.33%
Equipment (EQP)	1,250.00	0.00	<input type="text" value="0"/>	0.00	168,750.00	7.50%
Overseas Travel (OT)	0.00	0.00	<input type="text" value="0"/>	0.00	150,000.00	0.00%
Research Scholarship (RS)	0.00	0.00	<input type="text" value="0"/>	0.00	150,000.00	0.00%
Indirect Cost (IDC)	4,000.00	0.00	0.00	0.00	136,000.00	9.33%
Total	8,750.00	0.00	0.00	0.00	841,250.00	6.53%

**Attach Supporting Document
(Advancement)**

Attachments sub-section in “Summary” page (Adv)

1 Third sub-section in summary page is Attachments. This section is to attach the file.

Add files...' button, for adding file.

2 Start upload' button. File types allowable include: txt, doc, pdf, zip, xls. Maximum size for each file is 4 MB.

3 Cancel upload, if that file is not require, can cancel that upload file before click on “start upload” button.

4 Delete ,remove the file., Below will display the attached file details.

Attachments

Please download the template(s) and upload the completed document(s) and other additional attachments (if any) in the form of Appendices under this section.

Instructions: Please click here to download the template(s). To add attachment, click the 'Add files...' button. Once completed, click the 'Start upload' button. File types allowable include: txt, doc, pdf, zip, xls, csv. The maximum size for each file is 4 MB.

+ Add files... Start upload Cancel upload Delete Download All

NOTE: The attached file(s) if any will be displayed after anti-virus scan is completed. Please wait and visit this page later.

File name	Size/Status	Actions	Check all
1.docx 18-Jun-2018 09:02 AM	578.71 KB	Delete	<input type="checkbox"/>

Back Next

Notes:

- Any HI Finance within the same Institution can View, Add, Delete and download all the attachments on the Fund requisition.
- In cases that that multiple HI Finance are accessing the same Fund requisition – the system will take the latest version that is saved or Submitted.

Attachments sub-section in “Summary” page (Adv)

5 Download All, will download all uploaded files.

6 Back button, will go to the back page.

7 Next” button will go to the next page

Attachments

Please download the template(s) and upload the completed document(s) and other additional attachments (if any) in the form of Appendices under this section.

Instructions: Please click here to download the template(s). To add attachment, click the 'Add files...' button. Once completed, click the 'Start upload' button. File types allowable include: txt, doc, pdf, zip, xls, csv. The maximum size for each file is 4 MB.

1 2 3 4 5

+ Add files... Start upload Cancel upload Delete Download All

NOTE: The attached file(s) if any will be displayed after anti-virus scan is completed. Please wait and visit this page later.

	File name	Size/Status	Actions	<input type="checkbox"/> Check all
	1.docx 18-Jun-2018 09:02 AM	578.71 KB	Delete	<input type="checkbox"/>

6 7

< Back Next ✓

Fund Requisition Line Amendment (Advancement)

Fund Request Line Amendment – Revise (Adv.)

1 To edit or revise uploaded each claim line, click hyperlink on S/N, and EOM pop-up page opened.

HI claim line details

Expenditure on Manpower (EOM) refers to the salary package (including annual increments, bonuses, staff welfare, medical and all other related benefits as per the Human Resource policies of your organisation) of the research staff employed under this grant.

Please provide the necessary descriptions and details to describe the Expenditure on Manpower (EOM) items to be claimed clearly. Note: Every item to be claimed must be able to be matched to the line item in the latest approved budget.

To add an item, click on the add button. To edit the line item, click on the hyperlink under the S/N column. To delete multiple lines, click select all and remove.

1 - 2 of 2 matching results found

S/N	Posting Date	Invoice/service rendered date	Account description	Document no.	Amount (\$\$)	Description	
EOM0001	21-Jan-2020	21-Jan-2020	Productisation of DT	1	500.00	Expenditure on Manpower (EOM) from Jan 2019 to Apr 2019	<input type="checkbox"/>
EOM0002	21-Jan-2020	21-Jan-2020	Productisation of DT	1	600.00	SME BLOOD TEXT FOR WORKING WITH LEAD	<input type="checkbox"/>

Select All ✓ Remove ✖ Add ⊕

Notes:

Each time amount updated on claim line, the amount will also updated to the calculation on summary page.

Fund Request Line Amendment – Revise (Adv.)

1 For MOE Tier 2 Grants, if the posting date inputted on the CSV file upload for **EOM** vote is more that **6 months** after the project end date the system will show that vote line item in red.

HI claim line details

Expenditure on Manpower (EOM) refers to the salary package (including annual increments, bonuses, staff welfare, medical and all other related benefits as per the Human Resource policies of your organisation) of the research staff employed under this grant.

Please provide the necessary descriptions and details to describe the Expenditure on Manpower (EOM) items to be claimed clearly. Note: Every item to be claimed must be able to be matched to the line item in the latest approved budget.

To add an item, click on the add button. To edit the line item, click on the hyperlink under the S/N column. To delete multiple lines, click select all and remove.

1 - 2 of 2 matching results found

S/N	Posting Date	Invoice Date	Account description	Document no.	Amount (\$\$)	Description	
EOM0001	19-Jan-2023	01-Jul-2019	Salaries	33754	20.00	Test	<input type="checkbox"/>
EOM0002	19-Dec-2023	01-Jul-2019	Salaries	33754	20.00	Test	<input type="checkbox"/>

Select All ✓ Remove ✖ Add ➕

2 For MOE Tier 2 Grants, if the posting date inputted on the CSV file upload for **RS** vote is more that **18 months** after the project end date the system will show that vote line item in red.

HI claim line details

Please note that the Research Scholarship (RS) category is not eligible for Indirect Costs. The rates to be claimed should adhere to the prevailing rates set by the Ministry of Education (MOE).

Please provide the necessary descriptions and details to describe the Research Scholarship (RS) items to be claimed clearly. Note: Every item to be claimed must be able to be matched to the line item in the latest approved budget.

To add an item, click on the add button. To edit the line item, click on the hyperlink under the S/N column. To delete multiple lines, click select all and remove.

1 - 2 of 2 matching results found

S/N	Posting Date	Invoice Date	Account description	Document no.	Amount (\$\$)	Description	
RS0001	19-Jan-2024	01-Jul-2019	Salaries	5000907576	20.00	Test	<input type="checkbox"/>
RS0002	19-Dec-2024	01-Jul-2019	Salaries	5000907576	20.00	Test	<input type="checkbox"/>

Select All ✓ Remove ✖ Add ➕

< Back Next ✓

Notes:

When red line is click the system will not allow to save the vote line until the posting date is revised.

Fund Request Line Amendment – Remove (Adv.)

1 To delete uploaded record, put cursor on selected record

2 Click remove button

3 Or to multiple selection, click select all, and delete.

HI claim line details

Expenditure on Manpower (EOM) refers to the salary package (including annual increments, bonuses, staff welfare, medical and all other related benefits as per the Human Resource policies of your organisation) of the research staff employed under this grant.

Please provide the necessary descriptions and details to describe the Expenditure on Manpower (EOM) items to be claimed clearly. Note: Every item to be claimed must be able to be matched to the line item in the latest approved budget.

To add an item, click on the add button. To edit the line item, click on the hyperlink under the S/N column. To delete multiple lines, click select all and remove.

1 - 2 of 2 matching results found

S/N	Posting Date	Invoice/service rendered date	Account description	Document no.	Amount (\$\$)	Description	
EOM0001	21-Jan-2020	21-Jan-2020	Productisation of DT	1	500.00	Expenditure on Manpower (EOM) from Jan 2019 to Apr 2019	<input type="checkbox"/>
EOM0002	21-Jan-2020	21-Jan-2020	Productisation of DT	1	600.00	SME BLOOD TEXT FOR WORKING WITH LEAD	<input type="checkbox"/>

Select All ✓ Remove - Add +

3

2

1

Fund Request Line Amendment – Add New Line (Adv.)

1 To Add/change each claim line on each VOTE, click add button fill all the mandatory fields.

2 **Save** button is used for save the entered value.

3 **Cancel** is used for canceling that dialogue box.

Notes:

Each time amount updated on claim line, the amount will also updated to the calculation on summary page.

HI claim line details

Expenditure on Manpower (EOM) refers to the salary package (including annual increments, bonuses, staff welfare, medical and all other related benefits as per the Human Resource policies of your organisation) of the research staff employed under this grant.

Please provide the necessary descriptions and details to describe the Expenditure on Manpower (EOM) items to be claimed clearly. Note: Every item to be claimed must be able to be matched to the line item in the latest approved budget.

To add an item, click on the add button. To edit the line item, click on the hyperlink under the S/N column. To delete multiple lines, click select all and remove.

1 - 2 of 2 matching results found

S/N	Posting Date	Invoice/service rendered date	Account description	Document no.	Amount (\$\$)	Description
EOM0001	21-Jan-2020	21-Jan-2020	Productisation of DT	1	500.00	Expenditure on Manpower (EOM) from Jan 2019 to Apr 2019
EOM0002	21-Jan-2020	21-Jan-2020	Productisation of DT	1	600.00	SME BLOOD TEXT FOR WORKING WITH LEAD

Select All ✓ Remove - Add +

Add/Change in Expenditure on Manpower (EOM)

Account no

Posting date

Invoice/service rendered date

Invoice no

Document no

PO no

PO date

Vendor name

Amount

Is fundable?

Fundable amount

Account description

Item description

Cancel ✕ Save ✓

1

3

2

Fund Requisition Submission (Advancement)

Fund Request Advancement – Submission (Adv.)

1 Once all page section marked as green (completed), HI Finance can submit Fund Request in declaration page. Name of HI Finance, by default user name who login.

2 Acknowledgement, the option whether the consent is acknowledge.

3 Key in any comments if required.

4 Date of acknowledgement, by default current system date will display.

search rship (RS) ✓ Exceptional Items (EI) ✓ Supplemental Human Capital Funding (SHC) ✓ Commitments OOE ✓ Commitments Equipment ✓ Manpower ✓ Declaration ✓

Declaration

[Hide Fund Details](#)

Fund requisition ID		Project ID	NRF-000905-01
Financial quarter	FY 2018 Q1	Award number	15May2018-Manual-LOA001
Submission date and time		Project start date	01-Jul-2016
Host institution	MU	Project end date	30-Jun-2021
HI claim no		Lead PI/Team PI	P92
Status	Draft		

Undertaking By HI Finance

We hereby certify that: The particulars provided above are true and correct, and verified against the original source documents. The same claim has not been requested previously. No claims for expenses before the 'Start date' and after the 'End date' of this project was made. This request has been made in accordance with the Investigatorship guidelines. Terms and conditions specified in the Letter of Award.

1 Name of HI Finance: p94 - ncs

2 Acknowledgement: Yes No

3 Comments: |

4 Date of acknowledgement: 18/05/2018

6 < Back

7 Save as Draft H

5 Submit ✓

Fund Request Advancement – Submission (Adv.)

5 Submit, to submit Fund Request to IGMS system.

6 Back, to switch back to the previous page.

7 Save as Draft, to saving the updated data by click on “save as draft” button

The screenshot shows the 'Declaration' section of a fund request submission form. At the top, there is a navigation bar with several tabs: 'search rship (RS)', 'Exceptional Items (EI)', 'Supplemental Human Capital Funding (SHC)', 'Commitments OOE', 'Commitments Equipment', 'Manpower', and 'Declaration'. The 'Declaration' tab is active. Below the navigation bar, there is a 'Declaration' header and a 'Hide Fund Details' link. The form contains a table of fund details, a 'Undertaking By HI Finance' section with a certification statement, and a form for providing HI Finance information. The form includes fields for 'Name of HI Finance', 'Date of acknowledgement', 'Acknowledgement' (Yes/No), and 'Comments'. At the bottom, there are buttons for 'Back', 'Save as Draft', and 'Submit'. Red numbered callouts (1-7) are placed over the form to indicate the steps described in the text on the left.

Fund Details		Project Details	
Fund requisition ID		Project ID	NRF-000905-01
Financial quarter	FY 2018 Q1	Award number	15May2018-Manual-LOA001
Submission date and time		Project start date	01-Jul-2016
Host institution	MU	Project end date	30-Jun-2021
HI claim no		Lead PI/Team PI	P92
Status	Draft		

Undertaking By HI Finance

We hereby certify that: The particulars provided above are true and correct, and verified against the original source documents. The same claim has not been requested previously. No claims for expenses before the 'Start date' and after the 'End date' of this project was made. This request has been made in accordance with the Investigatorship guidelines. Terms and conditions specified in the Letter of Award.

1 Name of HI Finance: p94 - ncs
2 Acknowledgement: Yes No
3 Comments:
4 Date of acknowledgement: 18/05/2018

6

Fund Request Advancement – Submission (Adv.)

1 After you click submit button, a confirmation message will appear. Click YES, to continue.

2 A confirmation message showing for successful submission. you will receive the information of Fund Request number from IGMS.

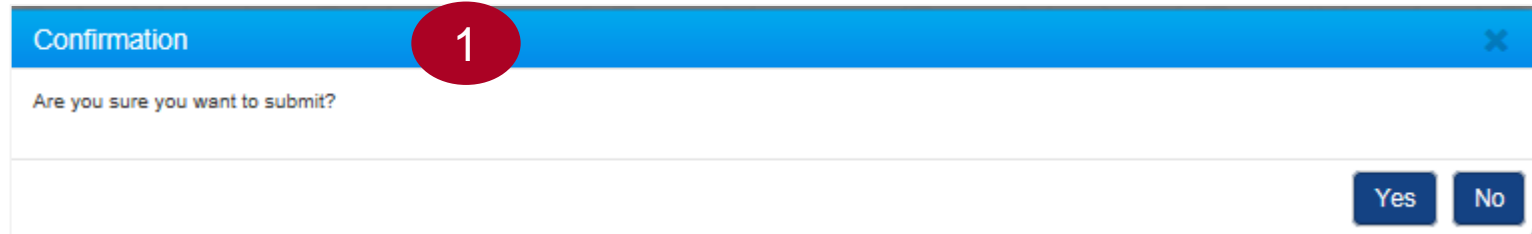

A screenshot of a web browser dialog box titled "Confirmation". The dialog has a blue header bar with the title and a close button (X) on the right. The main content area contains the text "Are you sure you want to submit?". At the bottom right, there are two buttons: "Yes" and "No". A red circle with the number "1" is overlaid on the top right corner of the dialog box.

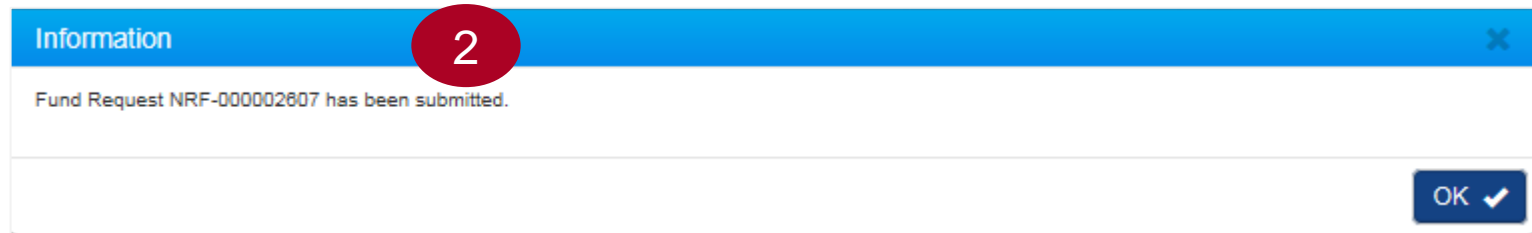

A screenshot of a web browser dialog box titled "Information". The dialog has a blue header bar with the title and a close button (X) on the right. The main content area contains the text "Fund Request NRF-000002607 has been submitted.". At the bottom right, there is one button: "OK" with a checkmark icon. A red circle with the number "2" is overlaid on the top right corner of the dialog box.

Understanding Statement of Account (SoA for Advancement Mode)

Statement of Account (SOA) – Understanding SOA

Final Statement of Account for Advancement:

- Final Statement of account (SOA) is the final claim submission for the project. All expenses claims for the project should be submitted in this claim.

Key Notes:

- Statement of Account should be submitted within 6 months from the project end date.
- Statement of Account only applicable for project with status **Pending Closure**. **No** submission will be allowed when the project status is closed.
- Only **one submission** will be accepted
- In case when project has been closed, but for any reason grantee need to do some **claim reversal**, a second submission will be allowed.
- Failure to submit SOA within the 6 months duration after project end date, will result in PI's automatic blacklisting, PI will not be able to apply for any open grants in IGMS.

Fund Requisition SoA – Create or Upload Claim

1 Click on *Projects > View Projects* to view Fund Requisition(s) submitted of respective Award/Project Refer to the Project Tracking Training Material for more details

2 Click on *Projects > Submit Claim* to create / upload a new Fund Requisition

3 Click on *Projects > View Claim Upload History* to check the status of Fund Requisition uploaded

4 Click on *Projects > Submit Cashflow Projection* to submit a cash flow projection.

These are the list of projects that are eligible to claim for the current period.

Upload Claim

1 - 10 of 470 matching results found

S/N	Project no.	Latest upload date	HI claim no.	Upload status	Fund Request status	Error details
1	ASTR-000064-01	14-May-2019	TST140519-03	Completed	None	
2	ASTR-000071-01			Pending	None	
3	ASTR-000072-01			Pending	None	
4	ASTR-000074-01			Pending	None	

Notes :

Cash Flow Projection is not mandatory for each Host Institution. HI can submit Cash flow projection if it is required.

Fund Requisition SoA – Create or Upload Claim

1 In submit claim page, we have two sub-sections as follows. "Upload claim" button is used for CSV claim file uploading.

2 Project no column will display the list of sub-projects hyperlink.

3 Last upload date is the last date for the csv claim file uploaded.

4 HI Claim No, is number specified by Grantee to identify the claim number for each submission

Home > Projects > Submit Claim

Claim submission

Project Running for Current Quarter

These are the list of projects that are eligible to claim for the current period.

[Upload Claim](#) 1

1 - 10 of 83 matching results found

5 6 7

S/N	Project no. 2	Latest upload date 3	HI claim no. 4	Upload status 5	Fund Request status 6	Error details 7
1	ASTR-000002-02			Pending	None	
2	ASTR-000003-01			Pending	None	
3	ASTR-000004-01			Pending	None	
4	ASTR-000005-01			Pending	None	
5	ASTR-000006-01			Pending	None	
6	ASTR-000012-01			Pending	None	
7	ASTR-000024-01			Pending	None	
8	ASTR-000026-01			Pending	None	
9	ASTR-000031-01			Pending	None	
10	ASTR-000032-01			Pending	None	

Fund Requisition SoA – Create or Upload Claim

5 Upload Status is upload claim file statuses. Statuses are :

- Pending, if there is no file has been uploaded, or upload in process
- Completed, if upload process has been completed.

6 Fund Request Status is the last Fund Request Status within a quarter or period. If Grantee has not submit any claim within a quarter/period, status will shown as **NONE**.

Home > Projects > Submit Claim

Claim submission

Project Running for Current Quarter

These are the list of projects that are eligible to claim for the current period.

Upload Claim **1**

1 - 10 of 83 matching results found

« < 1 2 3 4 5 > » **7**

S/N	Project no. 2	Latest upload date 3	HI claim no. 4	Upload status 5	Fund Request status 6	Error details 7
1	ASTR-000002-02			Pending	None	
2	ASTR-000003-01			Pending	None	
3	ASTR-000004-01			Pending	None	
4	ASTR-000005-01			Pending	None	
5	ASTR-000006-01			Pending	None	
6	ASTR-000012-01			Pending	None	
7	ASTR-000024-01			Pending	None	
8	ASTR-000026-01			Pending	None	
9	ASTR-000031-01			Pending	None	
10	ASTR-000032-01			Pending	None	

Fund Requisition SoA – Create or Upload Claim

7 Error details is to show if uploaded or created claim has violated a business validation.

Home > Projects > Submit Claim

Claim submission

Project Running for Current Quarter

These are the list of projects that are eligible to claim for the current period.

Upload Claim **1**

1 - 10 of 83 matching results found

5 **6** **7**

S/N	Project no. 2	Latest upload date 3	HI claim no. 4	Upload status 5	Fund Request status 6	Error details 7
1	ASTR-000002-02			Pending	None	
2	ASTR-000003-01			Pending	None	
3	ASTR-000004-01			Pending	None	
4	ASTR-000005-01			Pending	None	
5	ASTR-000006-01			Pending	None	
6	ASTR-000012-01			Pending	None	
7	ASTR-000024-01			Pending	None	
8	ASTR-000026-01			Pending	None	
9	ASTR-000031-01			Pending	None	
10	ASTR-000032-01			Pending	None	

Fund Requisition SoA – Create or Upload Claim

1 Claim submission page will display after click on “upload claim” in submit claim page

To download a CSV claim template, click the link to download.

2 HI claim number is mandatory for Grantee to specify a submission unique number.

3 To upload file, click attach files.

4 Click submit button.

The screenshot shows the 'HI claim submission' interface. At the top, there's a dark blue header with the text 'HI claim submission'. Below it, a section titled 'Hide Claim Details' shows the 'HI claim submission no' as 'f5017bab-5f46-4af7-9061-b503ee24e726', the 'Status' as 'Draft', and the 'Submission date and time' field. A blue bar labeled 'HI claims upload' contains instructions: 'Please click here to download template. To upload the claim, click the 'Attach files...' button. Once completed, click the 'Start upload' button. File types allowable: csv only. The maximum size for each file is 4 MB.' Below this, a light blue bar says '"Project ID" is mandatory. Please key in the "Project ID" for the claim submission'. A link 'Click here to download csv template.' is present. The 'HI claim no' field is empty, with a red circle '2' next to it. A red circle '1' is next to the mandatory project ID instruction. A red circle '3' is next to the '+ Attach files...' button. A red circle '4' is next to the 'Submit' button. A pink note box states: 'NOTE: The attached file(s) if any will be displayed after anti-virus scan is completed. Please wait and visit this page later.'

Fund Requisition SoA – Create or Upload Claim

5 After click on “submit “ button ,one dialogue box will display as follows “**File has been uploaded. An email notification will be sent shortly**”. Then click on “**OK**” button.

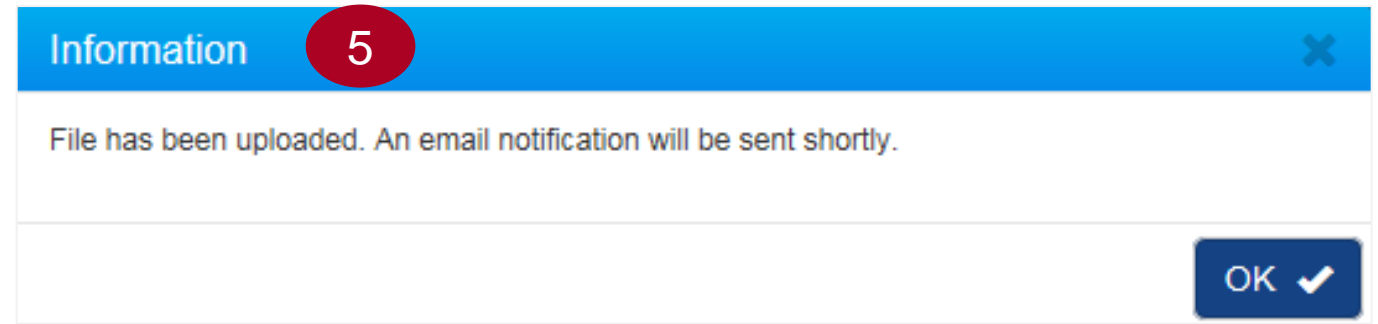

Notes:

- Multiple files can be uploaded simultaneously.
- Multiple projects can be grouped within one file.
- After uploaded, IGMS running a parsing file process.
- Once parsing process completed, HI Finance will receive notification either to submit (if successfully uploaded).
- Or, to revise and re-upload. (if file format validation is fail).
- This is for new Fund Requisition submissions only.
- For Fund Requisitions that have already been submitted and rejected, reupload the file under "Re-upload requisition details" (page 148).

Fund Requisition SoA – Create or Upload Claim

1 Claim upload history is a page to navigated the parsing process of uploaded claim/s. With this page, HI Finance can track the history of uploaded claim.
 HI Claim Submission No, is unique ID generated by IGMS each time claim is uploaded. This ID is unique according uploaded batch.

2 HI Claim No, is ID specified by Grantee to identified each time submission.

3 No of uploaded records, is number of claim line uploaded

View Claim Upload History

Upload History

The purpose of this page is to allow users to navigate the history of uploaded claims. Upload status include: In Progress, Completed and Failed. To obtain the details for the failed upload, please click on the error file.

Upload Claim

1 - 10 of 95 matching results found

S/N	HI claim submission no.	HI claim no	No of uploaded records	No of failed records	Submitted date & time	Upload status	Uploaded By	Error details
1	1f9ac8a9-b608-49a6-b018-5ec27b98e527	Sept 2018	0	399	09-05-2018 14:55:29	Failed	P93	Click here to download errors.
2	f5017bab-5f46-4af7-9061-b503ee24e726	Jun-Sept 2018-001	0	399	09-05-2018 14:33:35	Failed	ORE91	Click here to download errors.
3	27f95d8a-4647-40fe-9752-64dda08099f3	HI claim no 880	35	0	08-05-2018 14:48:03	Completed	OR5	
4	d40a5974-738c-4955-9d1c-fec05eb410ce	test	16	0	07-05-2018 17:01:30	Completed	p96	
5	68576ef1-e15f-485b-930f-d7f10ffbc265	142	0	399	07-05-2018 14:15:18	Failed	ORE91	Click here to download errors.
6	7cde8d2d-8941-4213-b38a-ae99d3700b94	2 testing	10	0	07-05-2018 14:11:29	Completed	P93	
7	afe60c7f-518d-4f84-b8a8-b642f1081403	test	16	0	07-05-2018 14:03:58	Completed	p96	

Verify Parsing File Result (SoA)

Understanding View Claim Upload History (SoA)

4 No failed records, is number of failed records to upload.

5 Submitted date and time, are date and time when the file has been uploaded

6 Upload Statuses are :

- Failed, file parsing process failed
- Completed, file parsing process completed

7 Uploaded by, is HI Finance user name that uploading the file.

View Claim Upload History

Upload History ▼

The purpose of this page is to allow users to navigate the history of uploaded claims. Upload status include: In Progress, Completed and Failed. To obtain the details for the failed upload, please click on the error file.

Upload Claim

1 - 10 of 95 matching results found

K
6
1
7
4
5
▶
8

S/N ▲	HI claim submission no. 1	HI claim no. 2	No of uploaded records 3	No of failed records 4	Submitted date & time	Upload status 5	Uploaded By 6	Error details 7
1	1f9ac8a9-b008-49a6-b018-5ec27b98e527	Sept 2018	0	399	09-05-2018 14:55:29	Failed	P93	Click here to download errors.
2	f5017bab-5f46-4af7-9061-b503ee24e726	Jun-Sept 2018-001	0	399	09-05-2018 14:33:35	Failed	ORE91	Click here to download errors.
3	27f95d8a-4647-40fe-9752-64dda08099f3	HI claim no 880	35					
4	d40a5974-738c-4955-9d1c-fec05eb410ce	test	16					
5	68576ef1-e15f-485b-930f-d7f10ffb265	142	0					
6	7cde8d2d-8941-4213-b38a-ae99d3700b94	2 testing	10					
7	afe60c7f-518d-4f84-b8a8-b642f1081403	test	16					

Notes :

IGMS will reject the whole claim file, if uploaded file/files does not meet the file validation criteria (slide 37 to 40)

Understanding View Claim Upload History (SoA)

8 Error file. Error file use to tracking the reason why the file is failed for validation.

View Claim Upload History

Upload History

The purpose of this page is to allow users to navigate the history of uploaded claims. Upload status include: In Progress, Completed and Failed. To obtain the details for the failed upload, please click on the error file.

Upload Claim

1 - 10 of 95 matching results found

5 6 1 7 4 5 > 8

S/N	HI claim submission no. 1	HI claim no. 2	No of uploaded records 3	No of failed records 4	Submitted date & time	Upload status	Uploaded By	Error details
1	1f9ac8a9-b608-49a6-b018-5ec27b98e527	Sept 2018	0	399	09-05-2018 14:55:29	Failed	P93	Click here to download errors.
2	f5017bab-5f48-4af7-9061-b503ee24e726	Jun-Sept 2018-001	0	399	09-05-2018 14:33:35	Failed	ORE91	Click here to download errors.
3	27f95d8a-4647-40fe-9752-64dda08099f3	HI claim no 880	35					
4	d40a5974-738c-4955-9d1c-fec05eb410ce	test	16					
5	68576ef1-e15f-485b-930f-d7f10fbc265	142	0					
6	7cde8d2d-8941-4213-b38a-ae99d3700b94	2 testing	10					
7	afe80c7f-518d-4f84-b8a8-b642f1081403	test	16					

Notes :

IGMS will reject the whole claim file, if uploaded file/files does not meet the file validation criteria (slide 37 to 40)

Understanding View Claim Upload History (SoA)

9

Once HI Finance click hyperlink to download the error file, IGMS will provide the details why uploaded file has error.

Line No, is the claim line number that causing an error/s

Error details is the invalid field value. Either because the data keyed in on the field is a wrong format, or if a mandatory information on each VOTES is missing.
(Details on slide 37-40)

Line No.	Error Details
15	Budget Category is empty
110	Posting Date is mandatory for EOM and RS
114	Account No is empty.Account Description is empty.Document No is empty.Item Description is empty.Amount is empty
118	Project Id is empty
171	Account No is empty.Account Description is empty.Document No is empty.Item Description is empty.Amount is empty
231	Account No is empty.Account Description is empty.Document No is empty.Item Description is empty.Amount is empty
247	Account No is empty.Account Description is empty.Document No is empty.Item Description is empty.Amount is empty
263	Document No is empty.PO Date is mandatory for EQP and EI.Vendor name is mandatory for EQP and EI
396	Account No is empty.Account Description is empty.Document No is empty.Item Description is empty.Amount is empty
397	Overseas Travel Date is mandatory for OT
398	Invoice No is mandatory for OOE or EQP or OT or EI.Invoice Date is mandatory for OOE or EQP or OT or EI.Overseas Travel Date

9

Fund Requisition Summary Page (Statement of Account - SoA)

Fund Requisition Summary Page (SoA)

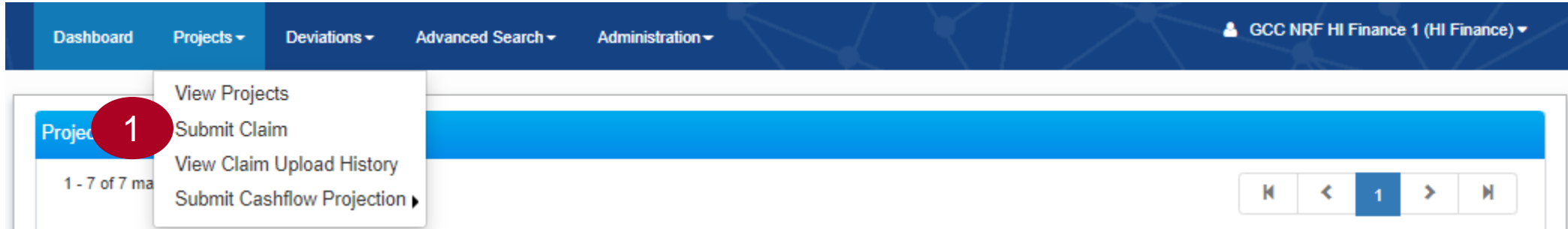

1 Once the Upload Status is “Completed”, navigate to Projects > Submit Claim, to view the list of projects for which a claim can be submitted.

2 Browse the list to find the FR record. Project Number indicates the Project ID and HI Claim No. displays the value entered by the user during claim upload.

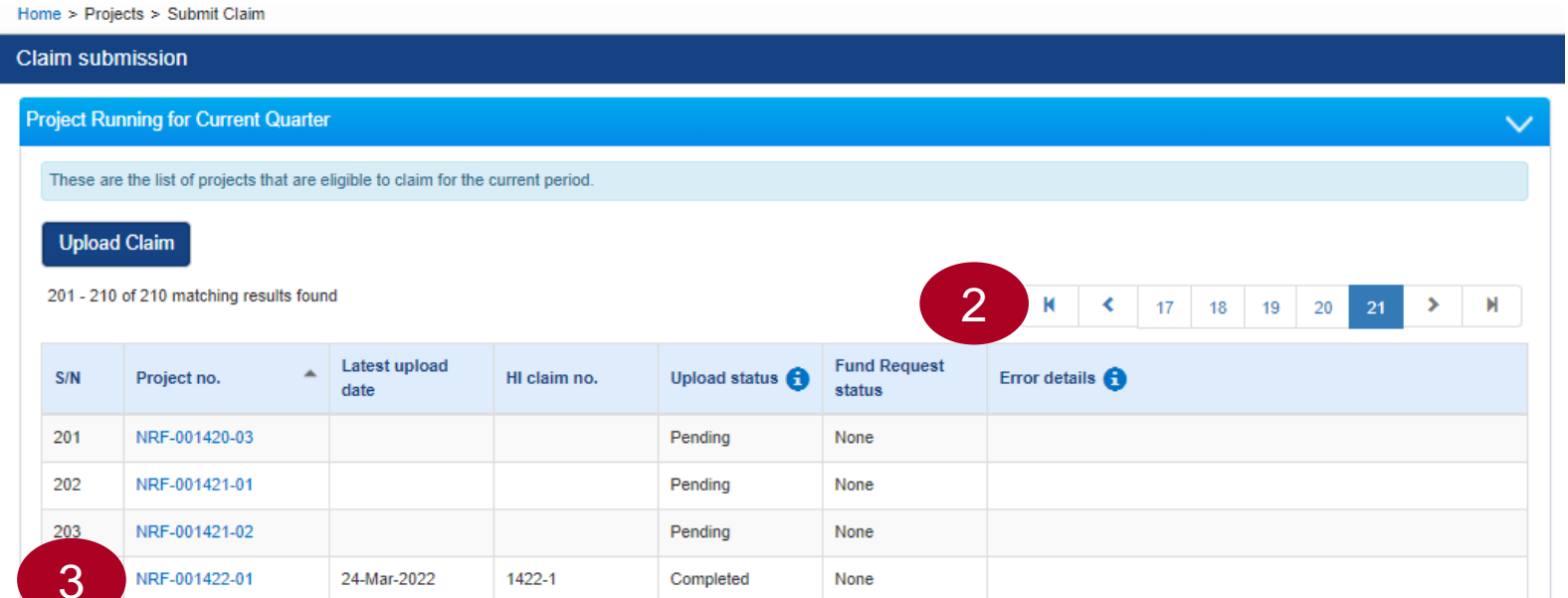

3 Click on the “Project no.” hyperlink to access the FR to complete the submission.

Fund Requisition Summary Page (SoA)

1 Is this final claim, is the flag once project reached the final claim. This flag is auto populated by system, once current date is after original project end date, or revised project end date.

2 Vote, is the budget type that applicable for the project.

3 Approved Budget, is the latest approved budget after virement.

4 Total Grant Received, is total cash advance amount that has been received by the Grantee.

Summary							
Is this final claim? Yes 1							
VOTE 2	Approved Budget 3	Total Grant Received 4	Cumulative Exp.Up to 31-Mar-2018 5	Exp. incurred in the current period ended 12 May-2018 6	Total Actual Expenditure incurred 7	Balance Grant to be returned to funding agency/(to be disbursed) 8	Budget Utilization 9
Expenditure on Manpower (EOM)	1,500,000.00	392,400.00	226,300.00	69,550.00	295,850.00	96,550.00	19.72%
Other Operating Expenditure (OOE)	900,000.00	297,124.14	245,250.73	95,210.86	340,461.59	-43,337.45	37.83%
Equipment (EQP)	1,000,000.00	383,104.20	349,656.30	125,372.69	475,028.99	-91,924.79	47.50%
Overseas Travel (OT)	250,000.00	53,417.54	23,876.31	7,958.77	31,835.08	21,582.46	12.73%
Supplemental Human Capital Funding (SHC)	250,000.00	20,000.00	0.00	0.00	0.00	20,000.00	0.00%
Indirect Cost (IDC)	1,095,000.00	337,813.76	253,525.00	89,427.70	342,952.70	-5,138.94	31.32%
Total	4,995,000.00	1,483,859.64	1,098,608.34	387,520.02	1,486,128.36	-2,268.72	29.75%

Fund Requisition Summary Page (SoA)

5 Cumulative expense up to previous 2 quarter, is the total expense until previous two quarters.

6 Expense incurred, is the expense on current submission.

7 Total actual expenditure, is total expense of project in all project duration. This column is calculated by column 5 add by column 6.

Summary ^								
Is this final claim? <input type="text" value="Yes"/> 1								
VOTE	2 Approved Budget	3 Total Grant Received	4 Cumulative Exp.Up to 31-Mar-2018	5 Exp. incurred in the current period ended 12 May-2018	6 Total Actual Expenditure incurred	7 Balance Grant to be returned to funding agency/(to be disbursed)	8 Budget Utilization	9
Expenditure on Manpower (EOM)	1,500,000.00	392,400.00	226,300.00	69,550.00	295,850.00	96,550.00	19.72%	
Other Operating Expenditure (OOE)	900,000.00	297,124.14	245,250.73	95,210.86	340,461.59	-43,337.45	37.83%	
Equipment (EQP)	1,000,000.00	383,104.20	349,656.30	125,372.69	475,028.99	-91,924.79	47.50%	
Overseas Travel (OT)	250,000.00	53,417.54	23,876.31	7,958.77	31,835.08	21,582.46	12.73%	
Supplemental Human Capital Funding (SHC)	250,000.00	20,000.00	0.00	0.00	0.00	20,000.00	0.00%	
Indirect Cost (IDC)	1,095,000.00	337,813.76	253,525.00	89,427.70	342,952.70	-5,138.94	31.32%	
Total	4,995,000.00	1,483,859.64	1,098,608.34	387,520.02	1,486,128.36	-2,268.72	29.75%	

Fund Requisition Summary Page (SoA)

8 Balance to be returned to Agency. Is the remaining last calculation amount. In positive means grantee has to return the over payment to Agency. In negative, means additional expenses need to pay by Agency.

9 Budget utilizations is total actual expenditures divided by approve budget.

Summary ^

Is this final claim? 1

VOTE 2	Approved Budget 3	Total Grant Received 4	Cumulative Exp.Up to 31-Mar-2018 5	Exp. incurred in the current period ended 12 May-2018 6	Total Actual Expenditure incurred 7	Balance Grant to be returned to funding agency/(to be disbursed) 8	Budget Utilization 9
Expenditure on Manpower (EOM)	1,500,000.00	392,400.00	228,300.00	69,550.00	295,850.00	96,550.00	19.72%
Other Operating Expenditure (OOE)	900,000.00	297,124.14	245,250.73	95,210.88	340,461.59	-43,337.45	37.83%
Equipment (EQP)	1,000,000.00	383,104.20	349,656.30	125,372.69	475,028.99	-91,924.79	47.50%
Overseas Travel (OT)	250,000.00	53,417.54	23,876.31	7,958.77	31,835.08	21,582.46	12.73%
Supplemental Human Capital Funding (SHC)	250,000.00	20,000.00	0.00	0.00	0.00	20,000.00	0.00%
Indirect Cost (IDC)	1,095,000.00	337,813.76	253,525.00	89,427.70	342,952.70	-5,138.94	31.32%
Total	4,995,000.00	1,483,859.64	1,098,608.34	387,520.02	1,486,128.36	-2,268.72	29.75%

**Attach Supporting Document
(SoA)**

Statement of Account (SOA) – Understanding SOA

1 Another section in summary page for SOA is Attachments. This section is to attach supporting document for related Statement of Account. To add attachment, click the 'Add files...' button. Once completed.

2 Click the 'Start upload' button. File types allowable include: txt, doc, pdf, zip, xls. The maximum size for each file is 4 MB.

Attachments

Please download the template(s) and upload the completed document(s) and other additional attachments (if any) in the form of Appendices under this section.

Instructions: Please click here to download the template(s). To add attachment, click the 'Add files...' button. Once completed, click the 'Start upload' button. File types allowable include: txt, doc, pdf, zip, xls, csv. The maximum size for each file is 4 MB.

+ Add files... Start upload Cancel upload Delete Download All

NOTE: The attached file(s) if any will be displayed after anti-virus scan is completed. Please wait and visit this page later.

File name	Size/Status	Actions	Check all
1.docx 18-Jun-2018 09:02 AM	578.71 KB	Delete	<input type="checkbox"/>

< Back Next >

Notes:

- Any HI Finance within the same Institution can View, Add, Delete and download all the attachments on the Fund requisition.
- In cases that that multiple HI Finance are accessing the same Fund requisition – the system will take the latest version that is saved or Submitted.

Statement of Account (SOA) – Understanding SOA

3

Cancel upload, if that file is not require, can cancel that upload file before click on “start upload” button.

4

Delete ,remove the file., Below will display the attached file details.

5

Download All, will download all uploaded files.

6

“Back” button will go to the previous page.

7

“Next” button will go to the next page.

The screenshot shows the 'Attachments' section of a web application. It includes a header, instructions, a row of buttons, a note, a table of attachments, and navigation buttons. Red circles with numbers 1-7 point to specific elements: 1 points to '+ Add files...', 2 to 'Start upload', 3 to 'Cancel upload', 4 to 'Delete', 5 to 'Download All', 6 to the '< Back' button, and 7 to the 'Next >' button.

Attachments

Please download the template(s) and upload the completed document(s) and other additional attachments (if any) in the form of Appendices under this section.

Instructions: Please click here to download the template(s). To add attachment, click the 'Add files...' button. Once completed, click the 'Start upload' button. File types allowable include: bt, doc, pdf, zip, xls, csv. The maximum size for each file is 4 MB.

+ Add files... Start upload Cancel upload Delete Download All

NOTE: The attached file(s) if any will be displayed after anti-virus scan is completed. Please wait and visit this page later.

File name	Size/Status	Actions	<input type="checkbox"/> Check all
1.docx 18-Jun-2018 09:02 AM	578.71 KB	Delete	<input type="checkbox"/>

< Back Next >

Statement of Account (SoA) Line Amendment

SoA Line Amendment - Revise

1 To edit or revise uploaded each claim line, click hyperlink on S/N, and EOM pop-up page opened.

HI claim line details

Expenditure on Manpower (EOM) refers to the salary package (including annual increments, bonuses, staff welfare, medical and all other related benefits as per the Human Resource policies of your organisation) of the research staff employed under this grant.

Please provide the necessary descriptions and details to describe the Expenditure on Manpower (EOM) items to be claimed clearly. Note: Every item to be claimed must be able to be matched to the line item in the latest approved budget.

To add an item, click on the add button. To edit the line item, click on the hyperlink under the S/N column. To delete multiple lines, click select all and remove.

1 - 2 of 2 matching results found

S/N	Posting Date	Invoice/service rendered date	Account description	Document no.	Amount (\$\$)	Description	
EOM0001	21-Jan-2020	21-Jan-2020	Productisation of DT	1	500.00	Expenditure on Manpower (EOM) from Jan 2019 to Apr 2019	1
EOM0002	21-Jan-2020	21-Jan-2020	Productisation of DT	1	600.00	SME BLOOD TEXT FOR WORKING WITH LEAD	

Select All ✓ Remove ✖ Add ⊕

Notes:

Each time amount updated on claim line, the amount will also updated to the calculation on summary page.

SoA Line Amendment - Revise

1 For MOE Tier 2 Grants, if the posting date inputted on the CSV file upload for **EOM** vote is more than **6 months** after the project end date the system will show that vote line item in red.

2 For MOE Tier 2 Grants, if the posting date inputted on the CSV file upload for **RS** vote is more than **18 months** after the project end date the system will show that vote line item in red.

Notes:

When red line is click the system will not allow to save the vote line until the posting date is revised.

HI claim line details

Expenditure on Manpower (EOM) refers to the salary package (including annual increments, bonuses, staff welfare, medical and all other related benefits as per the Human Resource policies of your organisation) of the research staff employed under this grant.

Please provide the necessary descriptions and details to describe the Expenditure on Manpower (EOM) items to be claimed clearly. Note: Every item to be claimed must be able to be matched to the line item in the latest approved budget.

To add an item, click on the add button. To edit the line item, click on the hyperlink under the S/N column. To delete multiple lines, click select all and remove.

1 - 2 of 2 matching results found

S/N	Posting Date	Invoice Date	Account description	Document no.	Amount (\$\$)	Description	
EOM0001	19-Jan-2023	01-Jul-2019	Salaries	33754	20.00	Test	<input type="checkbox"/>
EOM0002	19-Dec-2023	01-Jul-2019	Salaries	33754	20.00	Test	<input type="checkbox"/>

Select All ✓ Remove - Add +

1

HI claim line details

Please note that the Research Scholarship (RS) category is not eligible for Indirect Costs. The rates to be claimed should adhere to the prevailing rates set by the Ministry of Education (MOE).

Please provide the necessary descriptions and details to describe the Research Scholarship (RS) items to be claimed clearly. Note: Every item to be claimed must be able to be matched to the line item in the latest approved budget.

To add an item, click on the add button. To edit the line item, click on the hyperlink under the S/N column. To delete multiple lines, click select all and remove.

1 - 2 of 2 matching results found

S/N	Posting Date	Invoice Date	Account description	Document no.	Amount (\$\$)	Description	
RS0001	19-Jan-2024	01-Jul-2019	Salaries	5000907576	20.00	Test	<input type="checkbox"/>
RS0002	19-Dec-2024	01-Jul-2019	Salaries	5000907576	20.00	Test	<input type="checkbox"/>

Select All ✓ Remove - Add +

< Back Next ✓

2

SoA Line Amendment - Remove

1 To delete uploaded record, put cursor on selected record

2 Click remove button

3 Or to multiple selection, click select all, and click remove button.

HI claim line details

Expenditure on Manpower (EOM) refers to the salary package (including annual increments, bonuses, staff welfare, medical and all other related benefits as per the Human Resource policies of your organisation) of the research staff employed under this grant.

Please provide the necessary descriptions and details to describe the Expenditure on Manpower (EOM) items to be claimed clearly. Note: Every item to be claimed must be able to be matched to the line item in the latest approved budget.

To add an item, click on the add button. To edit the line item, click on the hyperlink under the S/N column. To delete multiple lines, click select all and remove.

1 - 2 of 2 matching results found

S/N	Posting Date	Invoice/service rendered date	Account description	Document no.	Amount (S\$)	Description	
EOM0001	21-Jan-2020	21-Jan-2020	Productisation of DT	1	500.00	Expenditure on Manpower (EOM) from Jan 2019 to Apr 2019	<input type="checkbox"/>
EOM0002	21-Jan-2020	21-Jan-2020	Productisation of DT	1	600.00	SME BLOOD TEXT FOR WORKING WITH LEAD	<input type="checkbox"/>

Select All ✓ Remove - Add +

3

2

1

SoA Line Amendment – Add New Line

1 To Add/change each claim line on each VOTE, click add button fill all the mandatory fields.

2 **Save** button is used for save the entered value.

3 **Cancel** is used for canceling that dialogue box.

Notes:

Each time amount updated on claim line, the amount will also updated to the calculation on summary page.

HI claim line details

Expenditure on Manpower (EOM) refers to the salary package (including annual increments, bonuses, staff welfare, medical and all other related benefits as per the Human Resource policies of your organisation) of the research staff employed under this grant.

Please provide the necessary descriptions and details to describe the Expenditure on Manpower (EOM) items to be claimed clearly. Note: Every item to be claimed must be able to be matched to the line item in the latest approved budget.

To add an item, click on the add button. To edit the line item, click on the hyperlink under the S/N column. To delete multiple lines, click select all and remove.

1 - 2 of 2 matching results found

S/N	Posting Date	Invoice/service rendered date	Account description	Document no.	Amount (\$\$)	Description
EOM0001	21-Jan-2020	21-Jan-2020	Productisation of DT	1	500.00	Expenditure on Manpower (EOM) from Jan 2019 to Apr 2019
EOM0002	21-Jan-2020	21-Jan-2020	Productisation of DT	1	600.00	SME BLOOD TEXT FOR WORKING WITH LEAD

Select All Remove Add

Add/Change in Expenditure on Manpower (EOM)

Account no [] Posting date []

Invoice/service rendered date []

Invoice no [] Document no []

PO no [] PO date []

Amount [] Vendor name []

Is fundable?

Fundable amount []

Account description []

Item description []

3 Cancel Save 2

1

SOA - Submission

Statement of Account (SOA) - Submission

1

Once all page section marked as green (completed), HI Finance can submit Fund Request in declaration page. Name of HI Finance, by default user name who login.

2

Acknowledgement, the option whether the consent is acknowledge.

3

Key in any comments if required.

Home > Projects > Submit Claim > Declaration

Equipment (EQP) ✓ Overseas Travel (OT) ✓ Research Scholarship (RS) ✓ Exceptional Items (EI) ✓ Supplemental Human Capital Funding (SHC) ✓ Manpower ✓ Declaration →

Declaration

Expand All Sections

Hide Fund Details

Fund requisition ID	ASTRFR-000083	Project ID	ASTR-000031-01
Fiscal quarter	Q4	Award number	ASTR-ASTPST02-0036
Submission date and time	22-Feb-2018	Project start date	13-Oct-2017
Host institution	Data Storage Institute	Project end date	18-Feb-2018
HI claim no	96	Lead PI/Team PI	ASTAR PST PI 4
Status	Pending Resubmission		

Undertaking By HI Finance

We hereby certify that: The particulars provided above are true and correct, and verified against the original source documents. The same claim has not been requested previously. No claims for expenses before the 'Start date' and after the 'End date' of this project was made. This request has been made in accordance with the Investigatorship guidelines. Terms and conditions specified in the Letter of Award.

1 Name of HI Finance: ASTAR PST HI Finance 1

Date of acknowledgement: 18/06/2018

2 Acknowledgement: Yes No

3 Comments: 28feb18 test whether comments can be saved when toggling from 1 tab to another.

Action Trail

6 < Back

7 Save as Draft

5 Submit ✓

Statement of Account (SOA) - Submission

4 Date of acknowledgement, by default current system date will display.

5 Submit, to submit Fund Request to IGMS system.

6 Back, to switch back to the previous page

7 Save as Draft, to saving the updated data by click on "save as draft" button.

Home > Projects > Submit Claim > Declaration

ment (EQP) ✓ Overseas Travel (OT) ✓ Research Scholarship (RS) ✓ Exceptional Items (EI) ✓ Supplemental Human Capital Funding (SHC) ✓ Manpower ✓ Declaration →

Declaration Expand All Sections

[Hide Fund Details](#)

Fund requisition ID	ASTRFR-000083	Project ID	ASTR-000031-01
Fiscal quarter	Q4	Award number	ASTR-ASTPST02-0036
Submission date and time	22-Feb-2018	Project start date	13-Oct-2017
Host institution	Data Storage Institute	Project end date	18-Feb-2018
HI claim no	96	Lead PI/Team PI	ASTAR PST PI 4
Status	Pending Resubmission		

Undertaking By HI Finance

We hereby certify that: The particulars provided above are true and correct, and verified against the original source documents. The same claim has not been requested previously. No claims for expenses before the 'Start date' and after the 'End date' of this project was made. This request has been made in accordance with the Investigatorship guidelines. Terms and conditions specified in the Letter of Award.

1 Name of HI Finance Date of acknowledgement 4

2 Acknowledgement Yes No

3 Comments

Action Trail

6 < Back 7 Save as Draft 5 Submit

Statement of Account (SOA) - Submission

1 After you click submit button, a confirmation message will appear. Click YES, to continue.

2 A confirmation message showing for successful submission. you will receive the information of Fund Request number from IGMS.

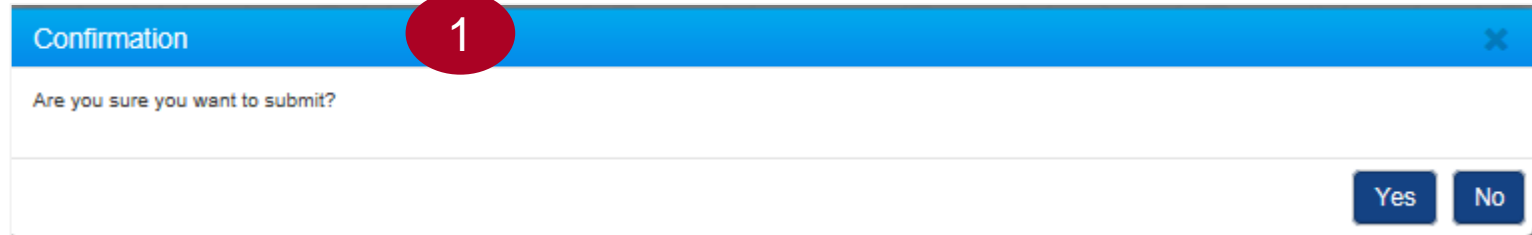

A screenshot of a web browser dialog box titled "Confirmation". The dialog has a blue header bar with the title "Confirmation" and a close button (X) on the right. The main content area contains the text "Are you sure you want to submit?". At the bottom right, there are two buttons: "Yes" and "No". A red circle with the number "1" is overlaid on the title bar.

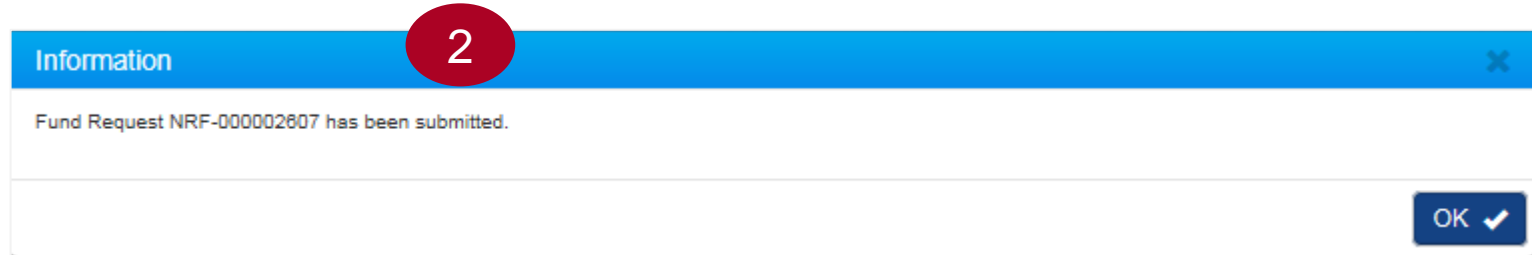

A screenshot of a web browser dialog box titled "Information". The dialog has a blue header bar with the title "Information" and a close button (X) on the right. The main content area contains the text "Fund Request NRF-000002607 has been submitted.". At the bottom right, there is one button: "OK" with a checkmark icon. A red circle with the number "2" is overlaid on the title bar.

Fund Requisition Reimbursement (Upload and Submission Process)

Reimbursement – Understanding Reimbursement Claim

Reimbursement :

If you are applied for grant call under managing agency NRF, MOE, or MOH all claim method is reimbursement.

Keynotes:

- In the beginning of each quarter you will receive email to submit a claim from previous quarter.
- Reimbursement method does not have commitment value. All claim lines need to specify as 'E (Expenses) upon uploading the claim file.
- Reimbursement method does not have commitment value. All claim lines need to specify as 'E (Expenses) upon uploading the claim file. Please refer to CSV template downloadable from IGMS.

Reimbursement (Final Claim) – Understanding Final Claim

Final Claim for Reimbursement:

- The Final claim for Reimbursement should be submitted within six(6) months after the Project End Date. All expenses claims for the project should be submitted in this claim.

Key Notes:

- The Final Claim should be submitted within 6 months from the project end date. Final claims that is submitted after six (6) months of project end date will not be allowed.
- The Final Claim is only applicable for project with status **Pending Closure**. **No** submission will be allowed when the project status is closed.
- Only **one submission** will be accepted. This is regardless of the quarter.
- The Final claim validation will apply on the HI Finance claim submission date.
- For resubmissions and claims that have been submitted successfully and pending action by HI HR, Agency Finance and PM, it will still be allowed to be processed even after the six (6) months period.
- Submission of Final claims is not allowed when the project status is **Closed**.

Fund Requisition – Create or Upload Claim (Reimb.)

1 Click on *Projects > View Projects* to view Fund Requisition(s) submitted of respective Award/Project Refer to the Project Tracking Training Material for more details

2 Click on *Projects > Submit Claim* to create / upload a new Fund Requisition

3 Click on *Projects > View Claim Upload History* to check the status of Fund Requisition uploaded

4 Click on *Projects > Submit Cashflow Projection* to submit a cash flow projection.

S/N	Project no.	Latest upload date	HI claim no.	Upload status	Fund Request status	Error details
1	ASTR-000064-01	14-May-2019	TST140519-03	Completed	None	
2	ASTR-000071-01			Pending	None	
3	ASTR-000072-01			Pending	None	
4	ASTR-000074-01			Pending	None	

Notes :

Cash Flow Projection is not mandatory for each Host Institution. HI can submit Cash flow projection if it is required.

Fund Requisition – Create or Upload Claim (Reimb.)

1 In submit claim page, we have two sub-sections as follows. "Upload claim" button is used for CSV claim file uploading.

2 Project no column will display the list of sub-projects hyperlink.

3 Last upload date is the last date for the csv claim file uploaded.

4 HI Claim No, is number specified by Grantee to identify the claim number for each submission

Home > Projects > Submit Claim

Claim submission

Project Running for Current Quarter

These are the list of projects that are eligible to claim for the current period.

[Upload Claim](#) 1

1 - 10 of 83 matching results found

5 6 7

S/N	Project no. 2	Latest upload date 3	HI claim no. 4	Upload status 5	Fund Request status 6	Error details 7
1	ASTR-000002-02			Pending	None	
2	ASTR-000003-01			Pending	None	
3	ASTR-000004-01			Pending	None	
4	ASTR-000005-01			Pending	None	
5	ASTR-000006-01			Pending	None	
6	ASTR-000012-01			Pending	None	
7	ASTR-000024-01			Pending	None	
8	ASTR-000026-01			Pending	None	
9	ASTR-000031-01			Pending	None	
10	ASTR-000032-01			Pending	None	

Fund Requisition – Create or Upload Claim (Reimb.)

5 Upload Status is upload claim file statuses. Statuses are :

- Pending, if there is no file has been uploaded, or upload in process
- Completed, if upload process has been completed.

6 Fund Request Status is the last Fund Request Status within a quarter or period. If Grantee has not submit any claim within a quarter/period, status will shown as **NONE**.

Home > Projects > Submit Claim

Claim submission

Project Running for Current Quarter

These are the list of projects that are eligible to claim for the current period.

Upload Claim **1**

1 - 10 of 83 matching results found

« < 1 2 3 4 5 > » **7**

S/N	Project no. 2	Latest upload date 3	HI claim no. 4	Upload status 5	Fund Request status 6	Error details 7
1	ASTR-000002-02			Pending	None	
2	ASTR-000003-01			Pending	None	
3	ASTR-000004-01			Pending	None	
4	ASTR-000005-01			Pending	None	
5	ASTR-000006-01			Pending	None	
6	ASTR-000012-01			Pending	None	
7	ASTR-000024-01			Pending	None	
8	ASTR-000026-01			Pending	None	
9	ASTR-000031-01			Pending	None	
10	ASTR-000032-01			Pending	None	

Fund Requisition – Create or Upload Claim (Reimb.)

7 Error details is to show if uploaded or created claim has violated a business validation.

Home > Projects > Submit Claim

Claim submission

Project Running for Current Quarter

These are the list of projects that are eligible to claim for the current period.

Upload Claim **1**

1 - 10 of 83 matching results found

5 6 **7**

S/N	Project no. 2	Latest upload date 3	HI claim no. 4	Upload status 5	Fund Request status 6	Error details 7
1	ASTR-000002-02			Pending	None	
2	ASTR-000003-01			Pending	None	
3	ASTR-000004-01			Pending	None	
4	ASTR-000005-01			Pending	None	
5	ASTR-000006-01			Pending	None	
6	ASTR-000012-01			Pending	None	
7	ASTR-000024-01			Pending	None	
8	ASTR-000026-01			Pending	None	
9	ASTR-000031-01			Pending	None	
10	ASTR-000032-01			Pending	None	

Fund Requisition – Create or Upload Claim (Reimb.)

1 Claim submission page will display after click on “upload claim” in submit claim page

To download a CSV claim template, click the link to download.

2 HI claim number is mandatory for Grantee to specify a submission unique number.

3 To upload file, click attach files.

4 Click submit button.

The screenshot shows the 'HI claim submission' page. At the top, there is a blue header with the text 'HI claim submission'. Below this, there is a section titled 'Hide Claim Details' with a chevron icon. Underneath, the 'HI claim submission no' is 'f5017bab-5f46-4af7-9061-b503ee24e726', the 'Status' is 'Draft', and the 'Submission date and time' is empty. Below this is a section titled 'HI claims upload' with a dropdown arrow. Inside this section, there is a light blue box with instructions: 'Please click here to download template. To upload the claim, click the 'Attach files...' button. Once completed, click the 'Start upload' button. File types allowable: csv only. The maximum size for each file is 4 MB.' Below this is another light blue box with the text: '"Project ID" is mandatory. Please key in the "Project ID" for the claim submission'. Below that is a light blue box with the text: 'Click [here](#) to download csv template.' Below this is a form field for 'HI claim no' with a red circle '2' next to it. Below the form field is a red box with the text: 'NOTE: The attached file(s) if any will be displayed after anti-virus scan is completed. Please wait and visit this page later.' Below the note is a blue button with a plus sign and the text '+ Attach files...' with a red circle '3' next to it. At the bottom right of the form is a blue button with the text 'Submit' and a checkmark, with a red circle '4' next to it.

Fund Requisition – Create or Upload Claim (Reimb.)

5 After click on “submit “ button ,one dialogue box will display as follows “**File has been uploaded. An email notification will be sent shortly**”. Then click on “**OK**” button.

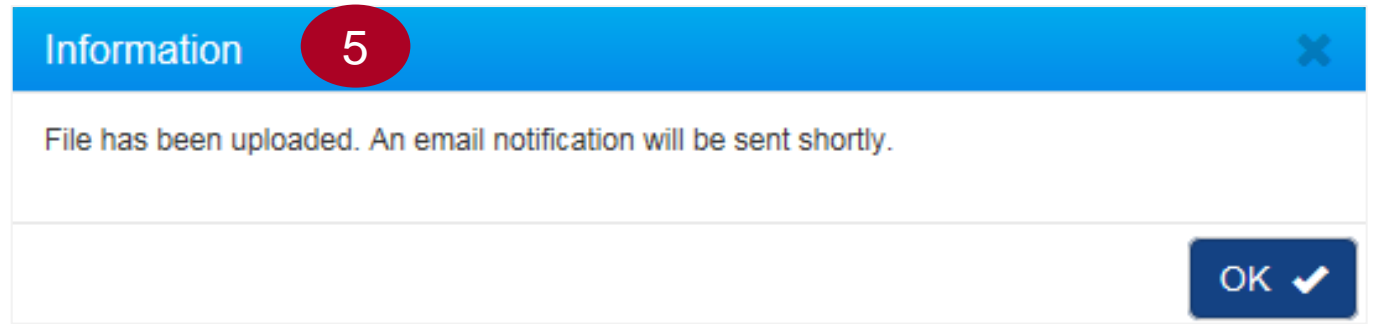

Notes:

- Multiple files can be uploaded simultaneously.
- Multiple projects can be grouped within one file.
- After uploaded, IGMS running a parsing file process.
- Once parsing process completed, HI Finance will receive notification either to submit (if successfully uploaded).
- Or, to revise and re-upload. (if file format validation is fail).
- This is for new Fund Requisition submissions only.
- For Fund Requisitions that have already been submitted and rejected, reupload the file under "Re-upload requisition details" (page 148).

Fund Requisition – Create or Upload Claim (Reimb.)

1 Claim upload history is a page to navigated the parsing process of uploaded claim/s. With this page, HI Finance can track the history of uploaded claim.
 HI Claim Submission No, is unique ID generated by IGMS each time claim is uploaded. This ID is unique according uploaded batch.

2 HI Claim No, is ID specified by Grantee to identified each time submission.

3 No of uploaded records, is number of claim line uploaded

View Claim Upload History

Upload History

The purpose of this page is to allow users to navigate the history of uploaded claims. Upload status include: In Progress, Completed and Failed. To obtain the details for the failed upload, please click on the error file.

Upload Claim

1 - 10 of 95 matching results found

S/N	HI claim submission no. 1	HI claim no 2	No of uploaded records 3	No of failed records 4	Submitted date & time	Upload status	Uploaded By	Error details
1	1f9ac8a9-b608-49a6-b018-5ec27b98e527	Sept 2018	0	399	09-05-2018 14:55:29	Failed	P93	Click here to download errors.
2	f5017bab-5f46-4af7-9061-b503ee24e726	Jun-Sept 2018-001	0	399	09-05-2018 14:33:35	Failed	ORE91	Click here to download errors.
3	27f95d8a-4647-40fe-9752-64dda08099f3	HI claim no 880	35	0	08-05-2018 14:48:03	Completed	OR5	
4	d40a5974-738c-4955-9d1c-fec05eb410ce	test	16	0	07-05-2018 17:01:30	Completed	p96	
5	68576ef1-e15f-485b-930f-d7f10ffbc265	142	0	399	07-05-2018 14:15:18	Failed	ORE91	Click here to download errors.
6	7cde8d2d-8941-4213-b38a-ae99d3700b94	2 testing	10	0	07-05-2018 14:11:29	Completed	P93	
7	afe60c7f-518d-4f84-b8a8-b642f1081403	test	16	0	07-05-2018 14:03:58	Completed	p96	

Verify Parsing File Result (Reimbursement)

Verify Parsing File Result (Reimb.)

4 No failed records, is number of failed records to upload.

5 Submitted date and time, are date and time when the file has been uploaded

6 Upload Statuses are :

- Failed, file parsing process failed
- Completed, file parsing process completed

7 Uploaded by, is HI Finance user name that uploading the file.

View Claim Upload History

Upload History

The purpose of this page is to allow users to navigate the history of uploaded claims. Upload status include: In Progress, Completed and Failed. To obtain the details for the failed upload, please click on the error file.

Upload Claim

1 - 10 of 95 matching results found

S/N	HI claim submission no.	HI claim no.	No of uploaded records	No of failed records	Submitted date & time	Upload status	Uploaded By	Error details
1	1f9ac8a9-b008-49a6-b018-5ec27b98e527	Sept 2018	0	399	09-05-2018 14:55:29	Failed	P93	Click here to download errors.
2	f5017bab-5f46-4af7-9061-b503ee24e726	Jun-Sept 2018-001	0	399	09-05-2018 14:33:35	Failed	ORE91	Click here to download errors.
3	27f95d8a-4647-40fe-9752-64dda08099f3	HI claim no 880	35					
4	d40a5974-738c-4955-9d1c-fec05eb410ce	test	16					
5	68576ef1-e15f-485b-930f-d7f10ffb265	142	0					
6	7cde8d2d-8941-4213-b38a-ae99d3700b94	2 testing	10					
7	afe60c7f-518d-4f84-b8a8-b642f1081403	test	16					

Notes :

IGMS will reject the whole claim file, if uploaded file/files does not meet the file validation criteria (slide 37 to 40)

Verify Parsing File Result (Reimb.)

8 Error file. Error file use to tracking the reason why the file is failed for validation.

View Claim Upload History

Upload History

The purpose of this page is to allow users to navigate the history of uploaded claims. Upload status include: In Progress, Completed and Failed. To obtain the details for the failed upload, please click on the error file.

Upload Claim

1 - 10 of 95 matching results found

S/N	HI claim submission no.	HI claim no.	No of uploaded records	No of failed records	Submitted date & time	Upload status	Uploaded By	Error details
1	1f9ac8a9-b608-49a6-b018-5ec27b98e527	Sept 2018	0	399	09-05-2018 14:55:29	Failed	P93	Click here to download errors.
2	f5017bab-5f48-4af7-9061-b503ee24e726	Jun-Sept 2018-001	0	399	09-05-2018 14:33:35	Failed	ORE91	Click here to download errors.
3	27f95d8a-4647-40fe-9752-64dda08099f3	HI claim no 880	35					
4	d40a5974-738c-4955-9d1c-fec05eb410ce	test	16					
5	68576ef1-e15f-485b-930f-d7f10fbc265	142	0					
6	7cde8d2d-8941-4213-b38a-ae99d3700b94	2 testing	10					
7	afe80c7f-518d-4f84-b8a8-b642f1081403	test	16					

Notes

IGMS will reject the whole claim file, if uploaded file/files does not meet the file validation criteria (slide 37 to 40)

Verify Parsing File Result (Reimb.)

9

Once HI Finance click hyperlink to download the error file, IGMS will provide the details why uploaded file has error.

Line No, is the claim line number that causing an error/s

Error details is the invalid field value. Either because the data keyed in on the field is a wrong format, or if a mandatory information on each VOTES is missing.
(Details on slide 37-40)

Line No.	Error Details
15	Budget Category is empty
110	Posting Date is mandatory for EOM and RS
114	Account No is empty.Account Description is empty.Document No is empty.Item Description is empty.Amount is empty
118	Project Id is empty
171	Account No is empty.Account Description is empty.Document No is empty.Item Description is empty.Amount is empty
231	Account No is empty.Account Description is empty.Document No is empty.Item Description is empty.Amount is empty
247	Account No is empty.Account Description is empty.Document No is empty.Item Description is empty.Amount is empty
263	Document No is empty.PO Date is mandatory for EQP and EI.Vendor name is mandatory for EQP and EI
396	Account No is empty.Account Description is empty.Document No is empty.Item Description is empty.Amount is empty
397	Overseas Travel Date is mandatory for OT
398	Invoice No is mandatory for OOE or EQP or OT or EI.Invoice Date is mandatory for OOE or EQP or OT or EI.Overseas Travel Date

Notes

Reimbursement method does not have commitment value. All claim lines need to specify as 'E (Expenses) upon uploading the claim file. Please refer to CSV template downloadable from IGMS.

Fund Requisition Summary Page (Reimbursement)

Fund Requisition Summary Page (Reimbursement)

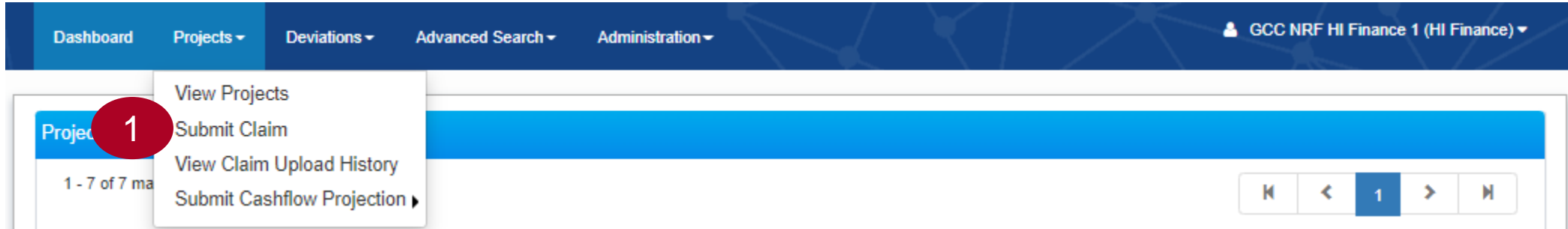

1 Once the Upload Status is “Completed”, navigate to Projects > Submit Claim, to view the list of projects for which a claim can be submitted.

2 Browse the list to find the FR record. Project Number indicates the Project ID and HI Claim No. displays the value entered by the user during claim upload.

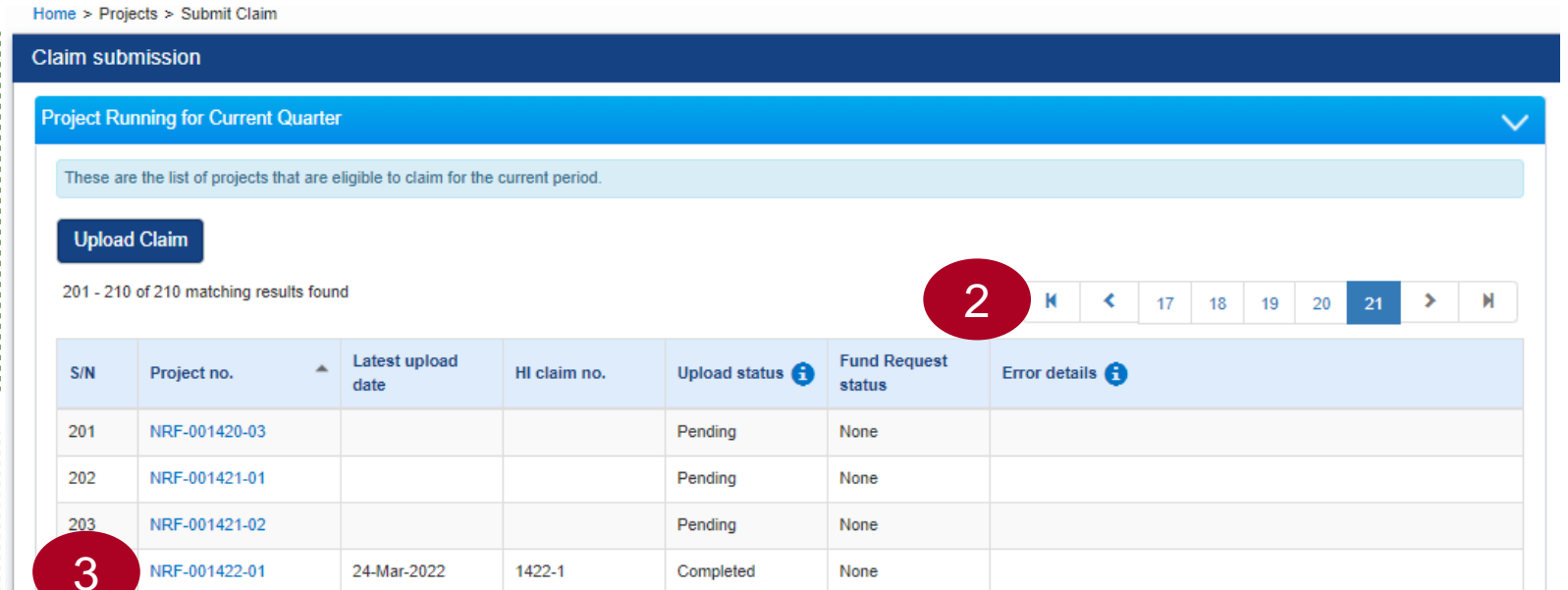

3 Click on the “Project no.” hyperlink to access the FR to complete the submission.

Fund Requisition Summary Page (Reimbursement)

On the Summary page of the Reimbursement, there are 3 new fields introduced for NRF funded projects.

1 The "Actual expenditure period from" and "Actual expenditure period to" fields should be filled up by HI Finance to specify the period (FY and QTR) of when the expenditures were incurred.

Refer to the next page for the points to take note.

Home > Projects > Submit Claim > Summary

Summary Expenditure on Manpower (EOM) Other Operating Expenditure (OOE) Equipment (EQP) Overseas Travel (OT) Research Scholarship (RS) Exception Items (E)

Summary Expand All Sections

[Hide Fund Details](#)

Fund requisition ID		Project ID	NRF-001422-01
Financial quarter	FY 2023 Q2	Award number	APOC19-01
Submission date and time		Project start date	24-Mar-2022
Host institution	GCC Host Institute test	Project end date	28-Feb-2024
HI claim no	1422-1	Lead PI/Team PI	GCC NRF PI 1
Actual Expenditure Period (From)	FY 2021 <input type="text"/>	Q4 <input type="text"/>	
Actual Expenditure Period (To)	FY 2021 <input type="text"/>	Q4 <input type="text"/>	
Status	Draft		

[Download Fund Request](#)

Fund Requisition Summary Page (Reimbursement)

To Note:

1. For the first FR submitted for a new project, the "Actual expenditure period from" and "Actual expenditure period to" will be defaulted to the Financial Year and Quarter of the Project Start Date.
2. For subsequent FRs, the Actual Expenditure Period will be defaulted to the next quarter after the last FR submission.
3. The Actual Expenditure Period can only be edited by the HI Finance when the FR is in "draft" status.
4. The 'Actual Expenditure Period From and To' must be within the same Financial Year.
5. For any claims that require 'Actual Expenditure Period From and To' to cross over FY, please inform your Agency Finance to amend the value in IGMS AX. Note: Under normal circumstances, claims should be submitted on a quarterly basis, and should not cross over FY. Such exceptional deviations will be strictly subjected to the Agency Finance's agreement.

Fund Requisition Summary Page (Reimbursement)

2

When there is an outstanding change in HI or Lead PI, the "Last Date of Sub-project" field will be available in the Fund Requisition for HI Finance to specify the last date of the sub project under the current HI or Lead PI.

The screenshot shows the 'Summary' page of a Fund Requisition. At the top, there are navigation tabs: Summary, Expenditure on Manpower (EOM), Other Operating Expenditure (OOE), Equipment (EQP), Overseas Travel (OT), Research Scholarship (RS), and Exceptional Items (E). The 'Summary' tab is active. Below the tabs, there is a 'Summary' section with a 'Hide Fund Details' link and an 'Expand All Sections' link. The summary is divided into two columns of fields. The left column includes: Fund requisition ID, Financial quarter (FY 2022 Q1), Submission date and time, Host institution (GCC Host Institute test), HI claim no, Actual Expenditure Period (From) (FY 2021), Actual Expenditure Period (To) (FY 2021), and Status (Draft). The right column includes: Project ID (NRF-001436-01), Award number (KMO_CR30_NONPO), Project start date (01-Dec-2021), Project end date (31-May-2023), Lead PI/Team PI (GCC NRF PI 1), and Last Date of Sub-project (29/03/2022). A red box highlights the 'Last Date of Sub-project' field and its instructions: 'Applicable to "Change in HI/PI" only: Please note that a request for change in HI/Lead PI has been submitted. If this is the Final Claim submitted under the former HI/Lead PI, please indicate the last date of the sub-project under the former HI/Lead PI. If this is NOT the Final Claim submitted under the former HI/Lead PI, please leave this field blank.' A red circle with the number '2' is placed over the instructions box.

To Note:

1. The "Last Date of Sub-project" field will appear in the FR if there is an outstanding deviation for Change in HI or Lead PI for the Sub Project.
2. The "Last Date of Sub-project" can be entered/edited by the HI Finance for FR status in "Draft" and "Pending Resubmission" status.

Fund Requisition Summary Page (Reimbursement)

1 The second sub-section in the Summary page is the Summary as shown below:
Vote is the budget category that is applicable for related project.

2 "Original Budget (B)" is the original awarded budget for project.

3 "Revised budget (C)" is the latest approved version budget for project.

4 Project budget by taking outstanding Virement/Trim/SHC into consideration (column C +/- Virement/Trim/Change in SHC).

VOTE	Original budget (B)	Revised budget (C)	Budget Balance After Proposed Virement and Trim (D)	Cumul exp. approved up to quarter ended 31-Dec-2019(E)	Exp. claimed in the quarter 31-Mar-2020(F)	Total exp. claimed up to quarter ended 31-Mar-2020(G=E+F)	Budget balances (H=D-G)	Budget utilisation I=(G/C)100
Expenditure on Manpower (EOM)	10,000.00	10,000.00	10,000.00	0.00	500.00	500.00	9,500.00	5.00%
Other Operating Expenditure (OOE)	10,000.00	10,000.00	10,000.00	0.00	500.00	500.00	9,500.00	5.00%
Equipment (EQP)	10,000.00	10,000.00	10,000.00	0.00	500.00	500.00	9,500.00	5.00%
Overseas Travel (OT)	10,000.00	10,000.00	10,000.00	0.00	0.00	0.00	10,000.00	0.00%
Supplemental Human Capital Funding (SHC)	0.00	0.00	0.00	0.00	0.00	0.00	0.00	0.00%
Indirect Cost (IDC)	0.00	0.00	0.00	0.00	<input type="text" value="0.00"/>	0.00	0.00	0.00%
Total	40,000.00	40,000.00	40,000.00	0.00	1,500.00	1,500.00	38,500.00	3.75%

5 Cumulative expense up to period is the total expenses, as of previous 2 quarters.

Fund Requisition Summary Page (Reimbursement)

6 Expenses claimed in quarter is the last quarter expenses that submitted on current submission.

7 Total expense claimed is total expense as of current submission, this column is calculation of column 4 add by column 5.

8 Budget balance is the remaining budget after deducted with cumulative expense up to current submission

9 Budget utilisation is calculation total expenses, divided by latest approved budget after virement.

VOTE	1 Original budget (B)	2 Revised budget (C)	3 Budget Balance After Proposed Virement and Trim (D)	4 Cumul exp. approved up to quarter ended 31-Dec-2019(E)	5 Exp. claimed in the quarter 31-Mar-2020(F)	6 Total exp. claimed up to quarter ended 31-Mar-2020(G=E+F)	7 Budget balances (H=D-G)	8 Budget utilisation I=(G/C)100
Expenditure on Manpower (EOM)	10,000.00	10,000.00	10,000.00	0.00	500.00	500.00	9,500.00	5.00%
Other Operating Expenditure (OOE)	10,000.00	10,000.00	10,000.00	0.00	500.00	500.00	9,500.00	5.00%
Equipment (EQP)	10,000.00	10,000.00	10,000.00	0.00	500.00	500.00	9,500.00	5.00%
Overseas Travel (OT)	10,000.00	10,000.00	10,000.00	0.00	0.00	0.00	10,000.00	0.00%
Supplemental Human Capital Funding (SHC)	0.00	0.00	0.00	0.00	0.00	0.00	0.00	0.00%
Indirect Cost (IDC)	0.00	0.00	0.00	0.00	<input type="text" value="0.00"/>	0.00	0.00	0.00%
Total	40,000.00	40,000.00	40,000.00	0.00	1,500.00	1,500.00	38,500.00	3.75%

**Attach Supporting Document
(Reimbursement)**

Attach Supporting Document (Reimb.)

1 Third sub-section in summary page is Attachments. This section is to attach the file.
Add files...' button, for adding file.

2 Start upload' button. File types allowable include: txt, doc, pdf, zip, xls. Maximum size for each file is 4 MB.

3 Cancel upload, if that file is not require, can cancel that upload file before click on "start upload" button.

4 Delete ,remove the file., Below will display the attached file details.

The screenshot shows the 'Attachments' section of a web application. At the top, there is a blue header with the title 'Attachments' and an upward arrow. Below the header, there is a light blue box containing instructions: 'Please download the template(s) and upload the completed document(s) and other additional attachments (if any) in the form of Appendices under this section.' and 'Instructions: Please click here to download the template(s). To add attachment, click the 'Add files...' button. Once completed, click the 'Start upload' button. File types allowable include: txt, doc, pdf, zip, xls, csv. The maximum size for each file is 4 MB.' Below the instructions, there are five buttons: '+ Add files...' (1), 'Start upload' (2), 'Cancel upload' (3), 'Delete' (4), and 'Download All' (5). A red note box below the buttons states: 'NOTE: The attached file(s) if any will be displayed after anti-virus scan is completed. Please wait and visit this page later.' Below the note is a table with columns: 'File name', 'Size/Status', 'Actions', and 'Check all'. The table contains one row with a file named '1.docx' (18-Jun-2018 09:02 AM) and a size of 578.71 KB. The 'Actions' column for this file has a red 'Delete' button. At the bottom of the interface, there are two buttons: '< Back' (6) and 'Next >' (7).

Notes:

- Any HI Finance within the same Institution can View, Add, Delete and download all the attachments on the Fund requisition.
- In cases that that multiple HI Finance are accessing the same Fund requisition – the system will take the latest version that is saved or Submitted.

Attach Supporting Document (Reimb.)

5 Download All, will download all uploaded files.

6 Back button, will go to the back page.

7 Next" button will go to the next page

The screenshot shows the 'Attachments' section of a web application. At the top, there is a blue header with the title 'Attachments' and an upward arrow. Below the header, a light blue box contains instructions: 'Please download the template(s) and upload the completed document(s) and other additional attachments (if any) in the form of Appendices under this section.' and 'Instructions: Please click here to download the template(s). To add attachment, click the 'Add files...' button. Once completed, click the 'Start upload' button. File types allowable include: txt, doc, pdf, zip, xls, csv. The maximum size for each file is 4 MB.' Below the instructions are five buttons: '+ Add files...' (1), 'Start upload' (2), 'Cancel upload' (3), 'Delete' (4), and 'Download All' (5). A pink note below the buttons reads: 'NOTE: The attached file(s) if any will be displayed after anti-virus scan is completed. Please wait and visit this page later.' Below the note is a table with columns: File name, Size/Status, Actions, and Check all. The table contains one row with a file named '1.docx' (18-Jun-2018 09:02 AM) and a 'Delete' button (6) in the Actions column. At the bottom of the interface are two buttons: '< Back' (6) and 'Next >' (7).

File name	Size/Status	Actions	Check all
1.docx 18-Jun-2018 09:02 AM	578.71 KB	Delete	<input type="checkbox"/>

Fund Requisition - Line Amendment (Reimbursement)

Fund Requisition Line Amendment – Revision (Reimb.)

1 To edit or revise uploaded each claim line, click hyperlink on S/N, and EOM pop-up page opened.

HI claim line details

Expenditure on Manpower (EOM) refers to the salary package (including annual increments, bonuses, staff welfare, medical and all other related benefits as per the Human Resource policies of your organisation) of the research staff employed under this grant.

Please provide the necessary descriptions and details to describe the Expenditure on Manpower (EOM) items to be claimed clearly. Note: Every item to be claimed must be able to be matched to the line item in the latest approved budget.

To add an item, click on the add button. To edit the line item, click on the hyperlink under the S/N column. To delete multiple lines, click select all and remove.

1 - 2 of 2 matching results found

S/N	Posting Date	Invoice/service rendered date	Account description	Document no.	Amount (\$\$)	Description	
EOM0001	21-Jan-2020	21-Jan-2020	Productisation of DT	1	500.00	Expenditure on Manpower (EOM) from Jan 2019 to Apr 2019	1
EOM0002	21-Jan-2020	21-Jan-2020	Productisation of DT	1	600.00	SME BLOOD TEXT FOR WORKING WITH LEAD	

Select All ✓ Remove - Add +

Notes:

Every time amount updated on each claim line, the amount will updated to summary page.

Fund Requisition Line Amendment – Revision (Reimb.)

1 For MOE Tier 2 Grants, if the posting date inputted on the CSV file upload for **EOM** vote is more that **6 months** after the project end date the system will show that vote line item in red.

HI claim line details

Expenditure on Manpower (EOM) refers to the salary package (including annual increments, bonuses, staff welfare, medical and all other related benefits as per the Human Resource policies of your organisation) of the research staff employed under this grant.

Please provide the necessary descriptions and details to describe the Expenditure on Manpower (EOM) items to be claimed clearly. Note: Every item to be claimed must be able to be matched to the line item in the latest approved budget.

To add an item, click on the add button. To edit the line item, click on the hyperlink under the S/N column. To delete multiple lines, click select all and remove.

1 - 2 of 2 matching results found

S/N	Posting Date	Invoice Date	Account description	Document no.	Amount (\$\$)	Description	
EOM0001	19-Jan-2023	01-Jul-2019	Salaries	33754	20.00	Test	<input type="checkbox"/>
EOM0002	19-Dec-2023	01-Jul-2019	Salaries	33754	20.00	Test	<input type="checkbox"/>

Select All ✓ Remove ✖ Add ➕

2 For MOE Tier 2 Grants, if the posting date inputted on the CSV file upload for **RS** vote is more that **18 months** after the project end date the system will show that vote line item in red.

HI claim line details

Please note that the Research Scholarship (RS) category is not eligible for Indirect Costs. The rates to be claimed should adhere to the prevailing rates set by the Ministry of Education (MOE).

Please provide the necessary descriptions and details to describe the Research Scholarship (RS) items to be claimed clearly. Note: Every item to be claimed must be able to be matched to the line item in the latest approved budget.

To add an item, click on the add button. To edit the line item, click on the hyperlink under the S/N column. To delete multiple lines, click select all and remove.

1 - 2 of 2 matching results found

S/N	Posting Date	Invoice Date	Account description	Document no.	Amount (\$\$)	Description	
RS0001	19-Jan-2024	01-Jul-2019	Salaries	5000907576	20.00	Test	<input type="checkbox"/>
RS0002	19-Dec-2024	01-Jul-2019	Salaries	5000907576	20.00	Test	<input type="checkbox"/>

Select All ✓ Remove ✖ Add ➕

< Back Next ✓

Notes:

When red line is click the system will not allow to save the vote line until the posting date is revised.

Fund Request Reimbursement – Remove Line (Reimb.)

1 To delete uploaded record, put cursor on selected record

2 Click remove button

3 Or to multiple selection, click select all, and delete.

HI claim line details

Expenditure on Manpower (EOM) refers to the salary package (including annual increments, bonuses, staff welfare, medical and all other related benefits as per the Human Resource policies of your organisation) of the research staff employed under this grant.

Please provide the necessary descriptions and details to describe the Expenditure on Manpower (EOM) items to be claimed clearly. Note: Every item to be claimed must be able to be matched to the line item in the latest approved budget.

To add an item, click on the add button. To edit the line item, click on the hyperlink under the S/N column. To delete multiple lines, click select all and remove.

1 - 2 of 2 matching results found

S/N	Posting Date	Invoice/service rendered date	Account description	Document no.	Amount (\$\$)	Description	
EOM0001	21-Jan-2020	21-Jan-2020	Productisation of DT	1	500.00	Expenditure on Manpower (EOM) from Jan 2019 to Apr 2019	<input type="checkbox"/>
EOM0002	21-Jan-2020	21-Jan-2020	Productisation of DT	1	600.00	SME BLOOD TEXT FOR WORKING WITH LEAD	<input type="checkbox"/>

Select All ✓ Remove - Add +

1

3

2

Fund Request Reimbursement – Add Line (Reimb.)

1 To Add/change each claim line on each VOTE, click add button fill all the mandatory fields.

2 **Save** button is used for save the entered value.

3 **Cancel** is used for canceling that dialogue box.

HI claim line details

Expenditure on Manpower (EOM) refers to the salary package (including annual increments, bonuses, staff welfare, medical and all other related benefits as per the Human Resource policies of your organisation) of the research staff employed under this grant.

Please provide the necessary descriptions and details to describe the Expenditure on Manpower (EOM) items to be claimed clearly. Note: Every item to be claimed must be able to be matched to the line item in the latest approved budget.

To add an item, click on the add button. To edit the line item, click on the hyperlink under the S/N column. To delete multiple lines, click select all and remove.

1 - 2 of 2 matching results found

S/N	Posting Date	Invoice/service rendered date	Account description	Document no.	Amount (S\$)	Description	
EOM0001	21-Jan-2020	21-Jan-2020	Productisation of DT	1	500.00	Expenditure on Manpower (EOM) from Jan 2019 to Apr 2019	<input type="checkbox"/>
EOM0002	21-Jan-2020	21-Jan-2020	Productisation of DT	1	600.00	SME BLOOD TEXT FOR WORKING WITH LEAD	<input type="checkbox"/>

Select All Remove Add

Add/Change in Expenditure on Manpower (EOM)

Account no

Posting date

Invoice/service rendered date

Invoice no

Document no

PO no

PO date

Vendor name

Amount

Is fundable?

Fundable amount

Account description

Item description

Cancel Save

1

3

2

Fund Requisition Reimbursement - Submission

Fund Request Reimbursement – Submission (Reimb.)

1 Once all page section marked as green (completed), HI Finance can submit Fund Request in declaration page.
Name of HI Finance, by default user name who login.

2 Acknowledgement, the option whether the consent is acknowledge.

3 Key in any comments if required.

Home > Projects > Submit Claim > Declaration

Equipment (EQP) ✓ Overseas Travel (OT) ✓ Research Scholarship (RS) ✓ Exceptional Items (EI) ✓ Supplemental Human Capital Funding (SHC) ✓ Manpower ✓ Declaration →

Declaration Expand All Sections

[Hide Fund Details](#)

Fund requisition ID	ASTRFR-000083	Project ID	ASTR-000031-01
Fiscal quarter	Q4	Award number	ASTR-ASTPST02-0036
Submission date and time	22-Feb-2018	Project start date	13-Oct-2017
Host institution	Data Storage Institute	Project end date	18-Feb-2018
HI claim no	96	Lead PI/Team PI	ASTAR PST PI 4
Status	Pending Resubmission		

Undertaking By HI Finance

We hereby certify that: The particulars provided above are true and correct, and verified against the original source documents. The same claim has not been requested previously. No claims for expenses before the 'Start date' and after the 'End date' of this project was made. This request has been made in accordance with the Investigatorship guidelines. Terms and conditions specified in the Letter of Award.

1 Name of HI Finance: ASTAR PST HI Finance 1 Date of acknowledgement: 18/06/2018 4

2 Acknowledgement: Yes No

3 Comments: 28feb18 test whether comments can be saved when toggling from 1 tab to another.

Action Trail

6 < Back 7 Save as Draft 5 Submit ✓

Fund Request Reimbursement – Submission (Reimb.)

4

Date of acknowledgement, by default current system date will display.

5

Submit, to submit Fund Request to IGMS system.

6

Back, to switch back to the previous page

7

Save as Draft, to saving the updated data by click on “save as draft” button.

Home > Projects > Submit Claim > Declaration

Equipment (EQP) ✓ Overseas Travel (OT) ✓ Research Scholarship (RS) ✓ Exceptional Items (EI) ✓ Supplemental Human Capital Funding (SHC) ✓ Manpower ✓ Declaration →

Declaration Expand All Sections

[Hide Fund Details](#)

Fund requisition ID	ASTRFR-000083	Project ID	ASTR-000031-01
Fiscal quarter	Q4	Award number	ASTR-ASTPST02-0036
Submission date and time	22-Feb-2018	Project start date	13-Oct-2017
Host institution	Data Storage Institute	Project end date	18-Feb-2018
HI claim no	96	Lead PI/Team PI	ASTAR PST PI 4
Status	Pending Resubmission		

Undertaking By HI Finance

We hereby certify that: The particulars provided above are true and correct, and verified against the original source documents. The same claim has not been requested previously. No claims for expenses before the 'Start date' and after the 'End date' of this project was made. This request has been made in accordance with the Investigatorship guidelines. Terms and conditions specified in the Letter of Award.

1 Name of HI Finance: ASTAR PST HI Finance 1

2 Acknowledgement: Yes No

3 Comments: 28feb18 test whether comments can be saved when toggling from 1 tab to another.

4 Date of acknowledgement: 18/06/2018

Action Trail

6 < Back

7 Save as Draft H

5 Submit ✓

Fund Request Reimbursement – Submission (Reimb.)

1 After you click submit button, a confirmation message will appear. Click YES, to continue.

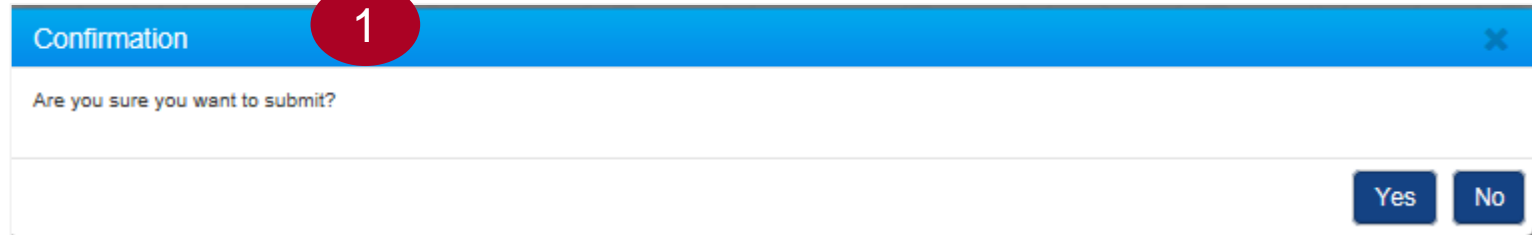

A screenshot of a confirmation dialog box. The title bar is blue and contains the word "Confirmation" and a red circle with the number "1". The main area is white and contains the text "Are you sure you want to submit?". At the bottom right, there are two buttons: "Yes" and "No".

2 A confirmation message showing for successful submission. you will receive the information of Fund Request number from IGMS.

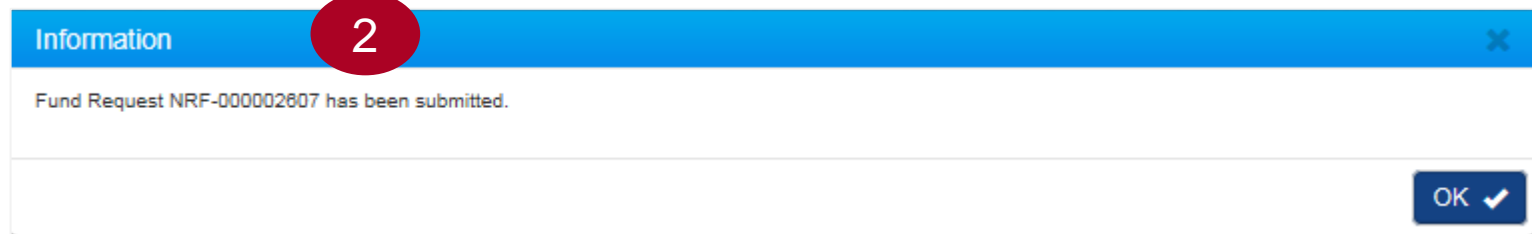

A screenshot of an information dialog box. The title bar is blue and contains the word "Information" and a red circle with the number "2". The main area is white and contains the text "Fund Request NRF-000002607 has been submitted.". At the bottom right, there is one button: "OK" with a checkmark icon.

Fund Requisition

1. Overview and Navigation of IGMS
2. Fund Requisition (Project Claim)
 - Understanding Fund Requisition
 - Fund Requisition Type
 - Fund Requisition Period (Claim Period)
 - Fund Requisition Status
 - Fund Requisition Pages
 - Fund Requisition Navigation Bar
 - Understanding Fund Requisition Upload Process
 - Upload File Validation
 - Business Validation
 - Understanding Fund Requisition Approval

Fund Requisition

- Upload and Submit Fund Requisition
 - Advancement
 - Statement of Account
 - Reimbursement
 - **Review and Re-upload Fund Requisition (All Methods)**
 - Editing calculated IDC for RIE 2015
3. Cash Flow Projection
- Create & Submit Cash Flow Projection
 - Review Cash Flow Projection
4. Download Fund Requisition

Review and Re-upload Fund Requisition (All Methods)

Review and Re-upload Fund Requisition (All Methods)

1

If the fund requisition is returned to HI Finance by HI HR (or PI for advancement Mode), or rejected by Agency Finance, the HI Finance can make amendments and re-upload the revised CSV file(s) by clicking the reference ID on the Dashboard.

Projects				
1 - 2 of 2 matching results found				
Date	Subject	Reference ID	Read	
04-May-2018	Fund requisition is pending for your amendment. To view details, click on reference ID	NRF-000002585	Yes	1
11-May-2018	Fund requisition is pending for your amendment. To view details, click on reference ID	NRF-000002557	No	

Notes :

HI Finance able to make amendment for the Fund Requisition, with these following condition :

- HI HR return
- PI Return (only applicable for Advancement method)
- Agency Finance reject the claim

Review and Re-upload Fund Requisition (All Methods)

1

If the fund requisition is returned to HI Finance by Agency Finance, the HI Finance is not allowed to make any amendment for the Fund Requisition, other than clarification.

Projects				
1 - 2 of 2 matching results found				
Date	Subject	Reference ID	Read	
04-May-2018	Fund requisition is pending for your amendment. To view details, click on reference ID	NRF-000002585	Yes	1
11-May-2018	Fund requisition is pending for your amendment. To view details, click on reference ID	NRF-000002557	No	

Notes :

Fund Request with status Pending HI Finance Clarification, is non editable by HI Finance. HI Finance can give clarification by navigating directly to the Undertaking page, and keying in the reply to Agency Finance.

Review and Re-upload Fund Requisition (All Methods)

1 Dashboard fields are :
Date is the date when the action is assigned to HI Finance.

2 Subject is the action item that need to be taken by HI Finance

3 Reference ID is the document ID.
Click this to navigate to the document source.

4 Read, is to indicate if the dashboard message has been read by the user.

Projects

1 - 2 of 2 matching results found

Date	Subject	Reference ID	Read
04-May-2018	Fund requisition is pending for your amendment. To view details, click on reference ID	NRF-000002585	Yes
11-May-2018	Fund requisition is pending for your amendment. To view details, click on reference ID	NRF-000002557	No

Review and Re-upload Fund Requisition (All Methods)

1 Once the reference ID is selected, you will be redirected to the Fund Request form. Go to the Action trail at the Summary page

2 Check the comment from the previous person who returned the record, to view the type of amendment required.

Notes :

You also can upload new attachment files under attachment section upon Fund Request amendment process.

Home > Projects > Submit Claim > Summary

Summary ✓ Expenditure on Manpower (EOM) ✓ Other Operating Expenditure (OOE) ✓ Equipment (EQP) ✓ Overseas Travel (OT) ✓ Research Scholarship (RS) ✓ Exceptional Items (EI) ✓

Summary Expand All Sections

Hide Fund Details

Fund requisition ID	NRF-002805	Project ID	NRF-001265-01
Financial quarter	FY 2020 Q4	Award number	NRF-RSS2025-0001
Submission date and time	05-Feb-2021	Project start date	19-Aug-2020
Host institution	GCC Host Institute	Project end date	18-Aug-2025
HI claim no		Lead PI/Team PI	GCC NRF PI 3
Status	Re-submitted for Approval		

[Download Fund Request](#)

Summary ✓ Attachments ✓ Re-upload requisition details ✓

Action Trail

1 - 2 of 2 matching results found

Date	Submitted by	Comments
05-Feb-2021	GCC NRF HI Finance 2	
24-Feb-2021	GCC NRF HI HR 1	

Review and Re-upload Fund Requisition (All Methods)

3 Go to the Re-upload Requisition details section to upload the revised CSV file(s).

Home > Projects > Submit Claim > Summary

Summary ✓ Expenditure on Manpower (EOM) ✓ Other Operating Expenditure (OOE) ✓ Equipment (EQP) ✓ Overseas Travel (OT) ✓ Research Scholarship (RS) ✓ Exception Items (EL) ✓

Summary Expand All Sections

[Hide Fund Details](#)

Fund requisition ID	NRF-002805	Project ID	NRF-001265-01
Financial quarter	FY 2020 Q4	Award number	NRF-RSS2025-0001
Submission date and time	05-Feb-2021	Project start date	19-Aug-2020
Host institution	GCC Host Institute	Project end date	18-Aug-2025
HI claim no		Lead PI/Team PI	GCC NRF PI 3
Status	Re-submitted for Approval		

[Download Fund Request](#)

Summary

Attachments

3 Re-upload requisition details

Please re upload the revised claim file. To upload the claim click the "Add files" button. Once completed, click the "Start Upload" button. File types allowed is *.csv only. The maximum size for each file is 4 mb.

Warning: The existing fund requisition lines will be overwritten with newly uploaded file. Please check your file prior to uploading.

[+ Add files...](#) [Start upload](#) [Cancel upload](#) [Delete](#) [Download All](#)

NOTE: The attached file(s) if any will be displayed after anti-virus scan is completed. Please wait and visit this page later.

File name	Size/Status	Actions	<input type="checkbox"/> Check all
-----------	-------------	---------	------------------------------------

Review and Re-upload Fund Requisition (All Methods)

1 Click "Add files" and attach the CSV file(s).

2 Click "Start" to upload the CSV file(s) attached.

3 Click "Cancel" to cancel the upload and remove the file.

Notes :

Once the file(s) are successfully uploaded, the fund requisition line items from the initial submission will be overwritten. Additionally, all fund requisition lines previously saved by any other users will be overwritten.

The screenshot shows the 'Summary' page of a fund requisition. At the top, there are navigation tabs for 'Summary', 'Expenditure on Manpower (EOM)', 'Other Operating Expenditure (OOE)', 'Equipment (EQP)', 'Overseas Travel (OT)', 'Research Scholarship (RS)', and 'Exception Items (EI)'. The 'Summary' tab is active and has a green checkmark. Below the tabs, the 'Summary' section is expanded, showing details for 'Hide Fund Details'. The details include: Fund requisition ID (NRF-002805), Project ID (NRF-001265-01), Financial quarter (FY 2020 Q4), Award number (NRF-RSS2025-0001), Submission date and time (05-Feb-2021), Project start date (19-Aug-2020), Host institution (GCC Host Institute), Project end date (18-Aug-2025), HI claim no, and Lead PI/Team PI (GCC NRF PI 3). The status is 'Re-submitted for Approval'. A 'Download Fund Request' button is located at the bottom right of the summary section. Below the summary, there are sections for 'Attachments' and 'Re-upload requisition details'. The 'Re-upload requisition details' section contains a message: 'Please re upload the revised claim file. To upload the claim click the "Add files" button. Once completed, click the "Start Upload" button. File types allowed is *.csv only. The maximum size for each file is 4 mb.' Below this message, there is a warning: 'Warning: The existing fund requisition lines will be overwritten with newly uploaded file. Please check your file prior to uploading.' At the bottom of this section, there are buttons for '+ Add files...', 'Start upload', 'Cancel upload', 'Delete', and 'Download All'. A red circle with the number '1' is placed over the 'Add files...' button. Below the buttons, there is a red banner with the text: 'NOTE: The attached file(s) if any will be displayed after anti-virus scan is completed. Please wait and visit this page later.' At the bottom of the page, there is a table with columns for 'File name', 'Size/Status', 'Actions', and a 'Check all' checkbox. The table contains one row with the file name 'FR_Template1.csv' and a size of '67.97 KB'. The 'Actions' column for this row contains 'Start' and 'Cancel' buttons. Red circles with the numbers '2' and '3' are placed over the 'Start' and 'Cancel' buttons, respectively.

File name	Size/Status	Actions	<input type="checkbox"/> Check all
FR_Template1.csv	67.97 KB	Start Cancel	

Review and Re-upload Fund Requisition (All Methods)

5 After clicking on “Start” button, a dialog box will display as follows “File has been uploaded. An email notification will be sent shortly”. Click on the “OK” button.

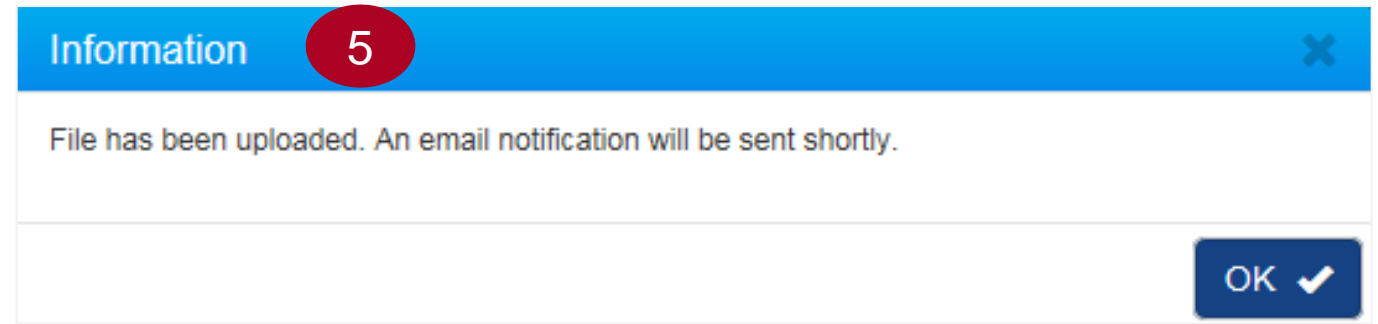

Notes:

- Multiple files can be uploaded simultaneously.
- As this is a re-upload file, you may only upload expenditure line items related to the project.
- After upload, IGMS will run a parsing file process. Refer to page 127 for verifying the parsing file results.

Review and Re-upload Fund Requisition (All Methods)

6 Click "Delete" to remove a CSV file that was previously uploaded.

Notes:

- You are only allowed to delete the file(s) the you uploaded.

The screenshot shows the 'Summary' page of a fund requisition. At the top, there are navigation tabs for various categories: Summary, Expenditure on Manpower (EOM), Other Operating Expenditure (OOE), Equipment (EQP), Overseas Travel (OT), Research Scholarship (RS), and Exception Items (E). The 'Summary' tab is active and has a green checkmark. Below the tabs, there is a 'Summary' section with a 'Hide Fund Details' link. The details include: Fund requisition ID (NRF-002805), Financial quarter (FY 2020 Q4), Submission date and time (05-Feb-2021), Host institution (GCC Host Institute), HI claim no, Status (Re-submitted for Approval), Project ID (NRF-001265-01), Award number (NRF-RSS2025-0001), Project start date (19-Aug-2020), Project end date (18-Aug-2025), and Lead PI/Team PI (GCC NRF PI 3). A 'Download Fund Request' button is located on the right. Below the details, there are sections for 'Summary', 'Attachments', and 'Re-upload requisition details'. The 'Re-upload requisition details' section contains instructions for uploading a revised claim file, a warning about overwriting existing lines, and buttons for '+ Add files...', 'Start upload', 'Cancel upload', 'Delete', and 'Download All'. A red box highlights the 'Delete' button. Below the buttons, there is a table with one row of file information:

File name	Size/Status	6	ns	<input type="checkbox"/> Check all
FR_Template1.csv 28-May-2021 11:53 AM	67.97 KB	Delete	<input type="checkbox"/>	

Review and Re-upload Fund Requisition (All Methods)

1 When the Fund Requisition status is **Pending Resubmission**, HI Finance can also make manual amendments or revisions on each claim line. To edit or revise the claim line, click the S/N hyperlink to open the claim detail pop-up page.

HI claim line details

Expenditure on Manpower (EOM) refers to the salary package (including annual increments, bonuses, staff welfare, medical and all other related benefits as per the Human Resource policies of your organisation) of the research staff employed under this grant.

Please provide the necessary descriptions and details to describe the Expenditure on Manpower (EOM) items to be claimed clearly. Note: Every item to be claimed must be able to be matched to the line item in the latest approved budget.

To add an item, click on the add button. To edit the line item, click on the hyperlink under the S/N column. To delete multiple lines, click select all and remove.

1 - 2 of 2 matching results found

S/N	Posting Date	Invoice/service rendered date	Account description	Document no.	Amount (\$\$)	Description	
EOM0001	21-Jan-2020	21-Jan-2020	Productisation of DT	1	500.00	Expenditure on Manpower (EOM) from Jan 2019 to Apr 2019	<input type="checkbox"/>
EOM0002	21-Jan-2020	21-Jan-2020	Productisation of DT	1	600.00	SME BLOOD TEXT FOR WORKING WITH LEAD	<input type="checkbox"/>

Select All ✓ Remove ✖ Add ➕

Notes:

When the amount is updated for each claim line, the corresponding balances will be updated in the Fund Requisition Summary page.

Review and Re-upload Fund Requisition (All Methods)

1 To delete claim line(s), select the record(s) to be deleted

2 Click Remove button

3 To delete all claim lines, click Select All and then Remove.

HI claim line details

Expenditure on Manpower (EOM) refers to the salary package (including annual increments, bonuses, staff welfare, medical and all other related benefits as per the Human Resource policies of your organisation) of the research staff employed under this grant.

Please provide the necessary descriptions and details to describe the Expenditure on Manpower (EOM) items to be claimed clearly. Note: Every item to be claimed must be able to be matched to the line item in the latest approved budget.

To add an item, click on the add button. To edit the line item, click on the hyperlink under the S/N column. To delete multiple lines, click select all and remove.

1 - 2 of 2 matching results found

S/N	Posting Date	Invoice/service rendered date	Account description	Document no.	Amount (\$\$)	Description	
EOM0001	21-Jan-2020	21-Jan-2020	Productisation of DT	1	500.00	Expenditure on Manpower (EOM) from Jan 2019 to Apr 2019	<input type="checkbox"/>
EOM0002	21-Jan-2020	21-Jan-2020	Productisation of DT	1	600.00	SME BLOOD TEXT FOR WORKING WITH LEAD	<input type="checkbox"/>

Select All ✓ Remove - Add +

1

3

2

Review and Re-upload Fund Requisition (All Methods)

1 To add a claim line for the VOTE, click Add button and fill all the mandatory fields.

2 **Save** button is used for save the entered value.

3 **Cancel** is used for cancelling that dialogue box.

Notes :

Use the Re-upload requisition details function when you want to edit or revise multiple lines from a Fund Request that has already been submitted.

HI claim line details

Expenditure on Manpower (EOM) refers to the salary package (including annual increments, bonuses, staff welfare, medical and all other related benefits as per the Human Resource policies of your organisation) of the research staff employed under this grant.

Please provide the necessary descriptions and details to describe the Expenditure on Manpower (EOM) items to be claimed clearly. Note: Every item to be claimed must be able to be matched to the line item in the latest approved budget.

To add an item, click on the add button. To edit the line item, click on the hyperlink under the S/N column. To delete multiple lines, click select all and remove.

1 - 2 of 2 matching results found

S/N	Posting Date	Invoice/service rendered date	Account description	Document no.	Amount (\$\$)	Description	
EOM0001	21-Jan-2020	21-Jan-2020	Productisation of DT	1	500.00	Expenditure on Manpower (EOM) from Jan 2019 to Apr 2019	<input type="checkbox"/>
EOM0002	21-Jan-2020	21-Jan-2020	Productisation of DT	1	600.00	SME BLOOD TEXT FOR WORKING WITH LEAD	<input type="checkbox"/>

Select All ✓ Remove - Add +

Add/Change in Expenditure on Manpower (EOM)

Account no

Invoice no

PO no

Amount

Account description

Item description

Posting date

Invoice/service rendered date

Document no

PO date

Vendor name

Is fundable?

Fundable amount

Cancel ✕ Save ✓

1

3

2

Review and Re-upload Fund Requisition (All Methods)

1 Once all page sections are marked as green (completed), HI Finance can submit Fund Request in the Declaration page. The Name of HI Finance, will show by default the user name who is logged in.

2 Acknowledgement, the option to confirm that the fund requisition is acknowledged.

3 Comment, is to key in a specific comment to the next party (HI HR or PI).

The screenshot shows a web interface for submitting a fund requisition. At the top, a navigation bar contains several categories, each with a green checkmark indicating completion: Equipment (EQP), Overseas Travel (OT), Research Scholarship (RS), Exceptional Items (EI), Supplemental Human Capital Funding (SHC), Manpower, and Declaration. A red circle with the number '1' is placed over the Declaration button.

Below the navigation bar is the 'Declaration' section. It features a 'Hide Fund Details' link and a table of requisition information:

Fund requisition ID	NRF-002703	Project ID	NRF-000903-01
Financial quarter	FY 2019 Q4	Award number	201DC
Submission date and time	09-Jan-2020	Project start date	08-Jan-2020
Host institution	NUS	Project end date	30-Jun-2020
HI claim no		Lead PI/Team PI	NCS PST PI 1
Status	Re-submitted for Approval		

Below the table is the 'Undertaking By HI Finance' section. It contains a certification statement: "I hereby certify that: The details provided above are true and correct, and verified against the original source of documents. This request has been made in accordance with the Grantor's Guidelines, the Terms and Conditions and the Letter(s) of Award." Below this are input fields for 'Name of HI Finance' (pre-filled with 'NCS PST's HI Finances 1'), 'Date of acknowledgement' (pre-filled with '01/04/2020'), and 'Acknowledgement' (radio buttons for 'Yes' and 'No'). A red circle with the number '2' is placed over the 'Date of acknowledgement' field.

Below the input fields is a 'Comments' section with a text area for 'input comment here...'. A red circle with the number '3' is placed over this text area.

At the bottom of the page is an 'Action Trail' section with a 'Back' button and 'Save as Draft' and 'Submit' buttons.

Review and Re-upload Fund Requisition (All Methods)

4 Date of acknowledgement, will show the current system date by default and is non-editable.

5 Click Submit to re-submit Fund Requisition.

The screenshot shows a web form titled "Undertaking By HI Finance". At the top, there is a blue header bar with the title and a dropdown arrow. Below the header, a light blue box contains a certification statement: "I hereby certify that: The details provided above are true and correct, and verified against the original source of documents. This request has been made in accordance with the Grantor's Guidelines, the Terms and Conditions and the Letter(s) of Award." The form fields include: "Name of HI Finance" with the value "NCS PST's HI Finances 1"; "Date of acknowl" with the value "01/04/2020" and a calendar icon; "Acknowledgement" with radio buttons for "Yes" (selected) and "No"; and "Comments" with a text area containing "input comment here...". At the bottom, there is a blue "Action Trail" bar with a dropdown arrow. Below this bar are three buttons: "< Back", "Save as Draft" with a floppy disk icon, and "Submit" with a checkmark icon. Red circles with numbers 4 and 5 are overlaid on the "Date of acknowl" field and the "Submit" button, respectively.

Review and Re-upload Fund Requisition (All Methods)

1 Once you click on Submit button, an info-log will pop up for confirmation. To continue click, Yes.

2 After submission, you will receive confirmation that the Fund Request number is submitted.

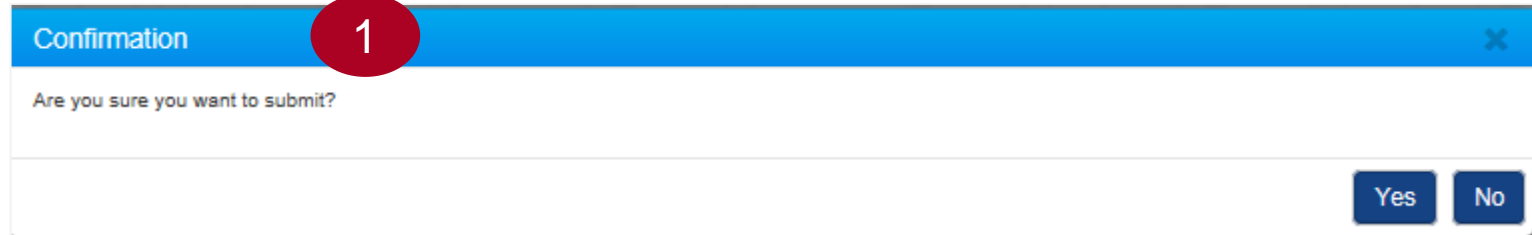

A confirmation dialog box with a blue header bar containing the word "Confirmation" and a red circle with the number "1". The main area contains the text "Are you sure you want to submit?". At the bottom right, there are two buttons: "Yes" and "No".

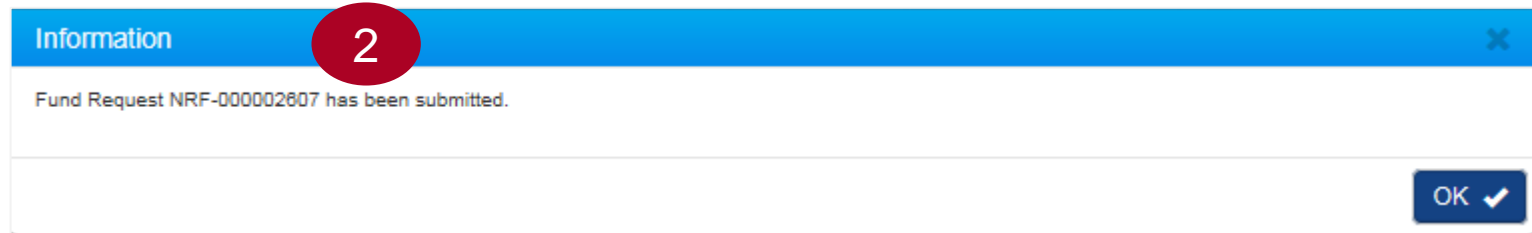

An information dialog box with a blue header bar containing the word "Information" and a red circle with the number "2". The main area contains the text "Fund Request NRF-000002607 has been submitted.". At the bottom right, there is a single button labeled "OK" with a checkmark icon.

Fund Requisition

1. Overview and Navigation of IGMS
2. Fund Requisition (Project Claim)
 - Understanding Fund Requisition
 - Fund Requisition Type
 - Fund Requisition Period (Claim Period)
 - Fund Requisition Status
 - Fund Requisition Pages
 - Fund Requisition Navigation Bar
 - Understanding Fund Requisition Upload Process
 - Upload File Validation
 - Business Validation
 - Understanding Fund Requisition Approval

Fund Requisition

- Upload and Submit Fund Requisition
 - Advancement
 - Statement of Account
 - Reimbursement
- Review and Re-upload Fund Requisition (All Methods)
- **Editing calculated IDC for RIE 2015**

3. Cash Flow Projection

- Create & Submit Cash Flow Projection
- Review Cash Flow Projection

4. Download Fund Requisition

Understanding IDC Calculation of IGMS

Understanding IDC Calculation of IGMS – 1

Below logics is running in the sequence order:

1. System supports up to 2 decimal points
2. IDC percentage is stored in Project Budget header as a total percentage of IPC% + IDC%. System inherits the percentage from Baseline
3. System checks whether or not the vote attracts IDC based on Grant Call setup
4. For vote(s) which attracts IDC, system calculates IDC **per line item and rounds it to 2 decimal digit**
5. System summaries total IDC amount
6. System stores the rounded total IDC amount

Understanding IDC Calculation of IGMS – 2

Example of IDC calculation of IGMS:

IDC = 23% (3 IPC % + 20 IDC %)

VOTE ITEM	AMOUNT	IDC Amount Rounded to 2 Decimal Place
EOM1	1,918.310	441.210
OOE1	1,218.670	280.290
OOE2	1,108.120	254.870
EQP1	8,109.380	1,865.160
EQP2	1,219.780	280.550
EQP3	1,901.430	437.330
OT1	-	-
RS1	-	-
SHC	1.240	0.290
TOTAL IDC		3,559.700
TOTAL DC		15,476.930
TOTAL AMOUNT		19,036.63

Understanding IDC for RIE 2015 in IGMS

Editing Calculated IDC for RIE 2015 – 1

- Specific for all project with Funding Tranche RIE 2015, system will allow calculated IDC to be editable
- By default system will calculate IDC amount according IDC percentage on the project level, and VOTES that applicable for IDC.
- Once default calculation is exceeding the remaining IDC budget per-project, HI Finance need to revise system calculated IDC amount.
- If your project has Overhead and IPC as IDC components, in IGMS, those 2 amounts will combined and sum up together.
- You will only need to specify / revise the combined IDC amount (Overhead + IPC Comm)
- In any cases, you will not able to submit Fund Request if exceed available budget for IDC.

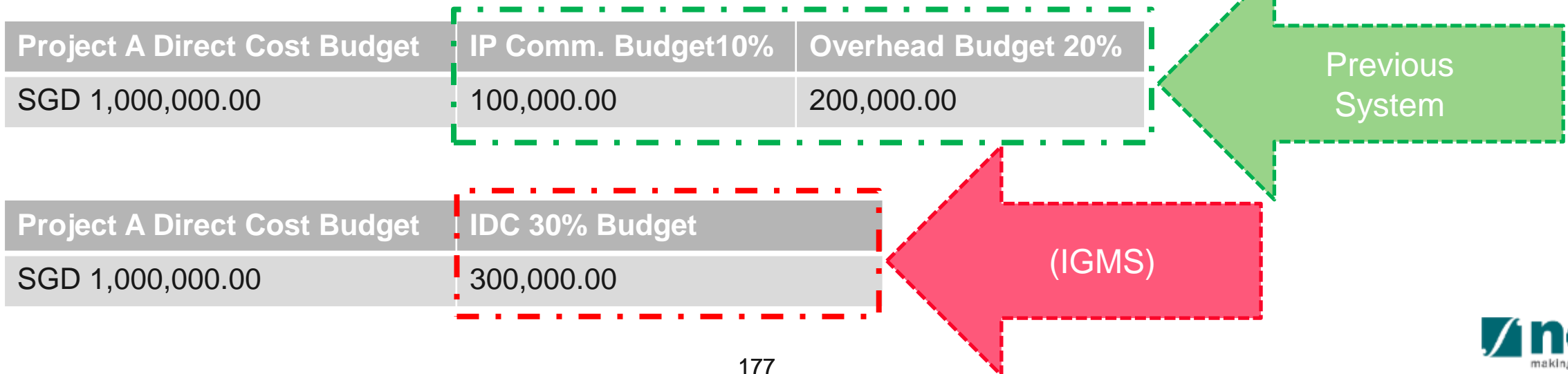

Editing IDC for RIE 2015 (Reimbursement Mode)

Editing Calculated IDC for RIE 2015 - Reimbursement

1 For reimbursement method, once parsing process of uploading claim finished, system will calculate IDC amount on column E. However, you can make revision for column E for Funding Tranche which allows editing IDC

2 If calculation of available budget is lesser than IDC claim amount, you will not be able to click next button. The page will not pass business validation. IDC claim amount in any case is not allowed to exceed IDC budget amount, after virement.

Summary 2

VOTE	Original budget (B)	Revised budget (C)	Budget Balance After Proposed Virement and Trim (D)	Cumul exp. approved up to quarter ended 31-Dec-2019(E)	Exp. claimed in the quarter 31-Mar-2020(F)	Total exp. claimed up to quarter ended 31-Mar-2020(G=E+F)	Budget balances (H=D-G)	Budget utilisation I=(G/C)100
Expenditure on Manpower (EOM)	10,000.00	10,000.00	10,000.00	0.00	500.00	500.00	9,500.00	5.00%
Other Operating Expenditure (OOE)	10,000.00	10,000.00	10,000.00	0.00	500.00	500.00	9,500.00	5.00%
Equipment (EQP)	10,000.00	10,000.00	10,000.00	0.00	500.00	500.00	9,500.00	5.00%
Overseas Travel (OT)	10,000.00	10,000.00	10,000.00	0.00	0.00	0.00	10,000.00	0.00%
Supplemental Human Capital Funding (SHC)	0.00	0.00	0.00	0.00	0.00	0.00	0.00	0.00%
Indirect Cost (IDC)	0.00	0.00	0.00	0.00	<input type="text" value="0.00"/>	0.00	0.00	0.00%
Total	40,000.00	40,000.00	40,000.00	0.00	1,500.00	1,500.00	38,500.00	3.75%

1

Editing Calculated IDC for RIE 2015 - Reimbursement

1 If you do manual revision for each claim line, system will not recalculate the IDC on summary page. System only recalculate the IDC, once you do upload file process.

HI claim line details

Expenditure on Manpower (EOM) refers to the salary package (including annual increments, bonuses, staff welfare, medical and all other related benefits as per the Human Resource policies of your organisation) of the research staff employed under this grant.

Please provide the necessary descriptions and details to describe the Expenditure on Manpower (EOM) items to be claimed clearly. Note: Every item to be claimed must be able to be matched to the line item in the latest approved budget.

To add an item, click on the add button. To edit the line item, click on the hyperlink under the S/N column. To delete multiple lines, click select all and remove.

1 - 2 of 2 matching results found

S/N	Posting Date	Invoice/service rendered date	Account description	Document no.	Amount (\$\$)	Description	
EOM0001	21-Jan-2020	21-Jan-2020	Productisation of DT	1	500.00	Expenditure on Manpower (EOM) from Jan 2019 to Apr 2019	<input type="checkbox"/>
EOM0002	21-Jan-2020	21-Jan-2020	Productisation of DT	1	600.00	SME BLOOD TEXT FOR WORKING WITH LEAD	<input type="checkbox"/>

Select All ✓ Remove ✖ Add ⊕

1

Editing IDC for RIE 2015 (Advancement Mode)

Editing Calculated IDC for RIE 2015 - Advancement

1

For advancement method, once parsing process of uploading claim finished, system will calculate IDC amount on column F. For expenses.

Summary							
VOTE	Original budget (B)	Revised budget (C)	Budget Balance After Proposed Virement and Trim (D)	Cumul fund received/ pending receipt up to 30-Sep-2017(E)	Cumul exp. up to 31-Mar-2017(F)	Exp. incurred in the period ended 30-Sep-2017(G)	Total exp. incurred up to 30-Sep-2017(H=F+G)
Expenditure on Manpower (EOM)	5,002,500.00	4,002,500.00	4,202,500.00	0.00	0.00	8,581.30	8,581.30
Other Operating Expenditure (OOE)	5,500,000.00	5,500,000.00	5,500,000.00	0.00	0.00	4,899.16	4,899.16
Equipment (EQP)	6,001,000.00	6,001,000.00	5,801,000.00	0.00	0.00	78,529.18	78,529.18
Overseas Travel (OT)	6,200,000.00	6,200,000.00	6,200,000.00	0.00	0.00	3,137.00	3,137.00
Research Scholarship (RS)	9,000,000.00	1,000,000.00	1,000,000.00	0.00	0.00	0.00	0.00
Indirect Cost (IDC)	3,170,350.00	3,070,350.00	3,070,350.00	0.00	0.00	798.13	798.13
Total	34,873,850.00	25,773,850.00	25,773,850.00	0.00	0.00	95,944.77	95,944.77

1

Editing Calculated IDC for RIE 2015 - Advancement

2 And calculated IDC from commitment after parsing file finished, will be calculated on column I.

3 After user projected the expense, user also need to specify projected IDC expense amount.

4 IDC claim amount in any case is not allow to exceeded IDC budget amount, after virement. If exceeded, you will not able to click next and submit the Fund Request.

Expenditure						
VOTE	Fund balance as at 31-Mar-2018(H=D-G)	Commitments (supported by POs) (I)	Projected exp. for current quarter (J)	Amount required for current quarter (K=I+J-H)	Budget balances (L=C-D-K)	Budget utilisation M= ((D+K)/C)100
Expenditure on Manpower (EOM)	-81,200.00	0.00	<input type="text" value="10000.00"/>	91,200.00	-66,780.00	135.15%
Other Operating Expenditure (OOE)	-95,974.86	0.00	<input type="text" value="10000.00"/>	105,974.86	-71,850.86	137.82%
Equipment (EQP)	-113,870.69	0.00	<input type="text" value="10000.00"/>	123,870.69	-116,876.69	161.51%
Overseas Travel (OT)	-7,958.77	0.00	<input type="text" value="10000.00"/>	17,958.77	16,374.23	91.38%
Research Scholarship (RS)	0.00	0.00	<input type="text" value="10000.00"/>	10,000.00	168,495.00	11.32%
Supplemental Human Capital Funding (SHC)	0.00	0.00	<input type="text" value="10000.00"/>	10,000.00	185,000.00	5.13%
Indirect Cost (IDC)	6,934.50	<input type="text" value="0.00"/>	<input type="text" value="10000.00"/>	3,065.50	144,098.34	24.16%
Total	-292,069.82	0.00	70,000.00	362,069.82	258,460.02	80.64%

Attachments	
<input type="button" value="Back"/>	<input type="button" value="Save as Draft"/> <input type="button" value="Next"/>

Editing Calculated IDC for RIE 2015 - Advancement

5

If you need system to re-compute the calculation of budget balance, after manual amendment of IDC, you can click save as a draft.

Expenditure
↑

VOTE	Fund balance as at 31-Mar-2018(H=D-G)	Commitments (supported by POs) (I)	Projected exp. for current quarter (J)	Amount required for current quarter (K=I+J-H)	Budget balances (L=C-D-K)	Budget utilisation M= ((D+K)/C)100
Expenditure on Manpower (EOM)	-81,200.00	0.00	<input type="text" value="10000.00"/>	91,200.00	-86,780.00	135.15%
Other Operating Expenditure (OOE)	-95,974.86	0.00	<input type="text" value="10000.00"/>	105,974.86	-71,850.86	137.82%
Equipment (EQP)	-113,870.69	0.00	<input type="text" value="10000.00"/>	123,870.69	-116,876.69	161.51%
Overseas Travel (OT)	-7,958.77	0.00	<input type="text" value="10000.00"/>	17,958.77	16,374.23	91.38%
Research Scholarship (RS)	0.00	0.00	<input type="text" value="10000.00"/>	10,000.00	168,495.00	11.32%
Supplemental Human Capital Funding (SHC)	0.00	0.00	<input type="text" value="10000.00"/>	10,000.00	185,000.00	5.13%
Indirect Cost (IDC)	6,934.50	<input type="text" value="0.00"/> 2	<input type="text" value="10000.00"/> 3	3,065.50	144,098.34	24.16%
Total	-292,069.82	0.00	70,000.00	362,069.82	258,460.02	80.64%

Attachments
5
4

← Back
Save as Draft
Next

Amendment in the Case of Insufficient Budget Balance

Amendment in the Case of Insufficient Budget Balance

1

When user clicks on the Next button, system prompts the error message because there is insufficient budget balance. System calculates budget balance by taking Virement / Trim / Change in SHC into consideration.

To amend, user can do the following:

1. HI HR/Agency Finance returns /rejects the FR to HI Finance for him/her to edit the Amount of FR line item, OR
2. PI edits the deviation, OR
3. DOR or PM rejects the deviation

The screenshot displays a web application interface. At the top, there is a 'Hide Fund Details' section with the following information:

- Fund requisition ID: NRF-002
- Financial quarter: FY 2019
- Submission date and time: 05-Mar-20
- Host institution: NUS
- HI claim no: CR57-07
- Status: Re-submitted for Approval

An error dialog box is overlaid on the screen with the following text:

Error
Please amend the claim amount, taking into consideration budget trim, virement, or change in SHC.
OK

Below the error message is the 'HI claim line details' section. It contains a text box with instructions: 'Expenditure on Manpower (EOM) refers to the salary package (including annual increments, bonuses, staff welfare, medical and all other related benefits as per the Human Resource policies of your organisation) of the research staff employed under this grant. Please provide the necessary descriptions and details to describe the Expenditure on Manpower (EOM) items to be claimed clearly. Note: Every item to be claimed must be able to be matched to the line item in the latest approved budget. To add an item, click on the add button. To edit the line item, click on the hyperlink under the S/N column. To delete multiple lines, click select all and remove.'

Below the text box is a table with 1 matching result found:

S/N	Posting Date	Invoice/service rendered date	Account description	Document no.	Amount (S\$)	Description
EOM0001	24-Mar-2020		new item	zx234	120.00	asd new item

At the bottom of the table, there are buttons for 'Select All', 'Remove', and 'Add'. At the very bottom of the page, there are 'Back' and 'Next' buttons.

Cash Flow Projection

Cash Flow Projection

1. Overview and Navigation of IGMS
2. Fund Requisition (Project Claim)
 - Understanding Fund Requisition
 - Fund Requisition Type
 - Fund Requisition Period (Claim Period)
 - Fund Requisition Status
 - Fund Requisition Pages
 - Fund Requisition Navigation Bar
 - Understanding Fund Requisition Upload Process
 - Upload File Validation
 - Business Validation
 - Understanding Fund Requisition Approval

Cash Flow Projection

- Upload and Submit Fund Requisition
 - Advancement
 - Statement of Account
 - Reimbursement
- Review and Re-upload Fund Requisition (All Methods)
- Editing calculated IDC for RIE 2015

3. Cash Flow Projection

- Create & Submit Cash Flow Projection
- Review Cash Flow Projection

4. Download Fund Requisition

Understanding Cash Flow Projection

Cash Flow Projection

- In the beginning of Quarter, Grantee/Host Institution will receive email notification to submit Cash Flow Projections.
- Cash Flow Projection in IGMS submitted in a Programme level
- Upon submission, system will calculated all project budgets, within one Grantee/Host Institution and grouped by Grant Programme.

Cash Flow Projection Workflow

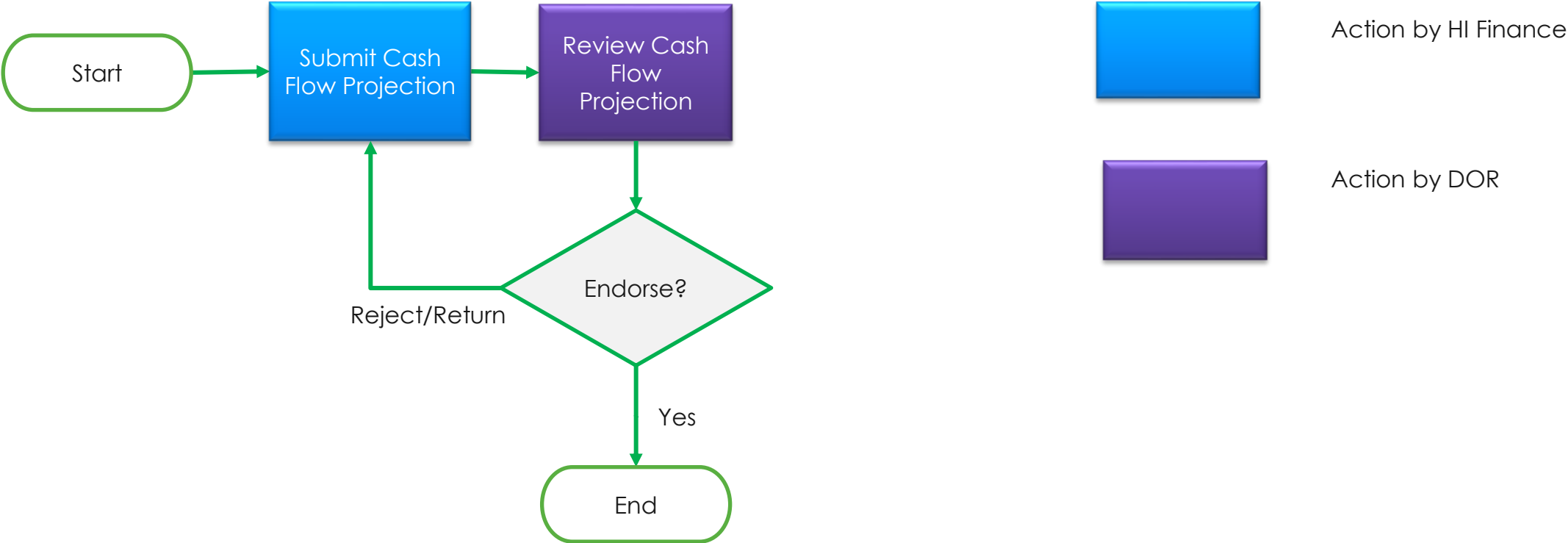

Create Cash Flow Projection

Create & Submit Cash Flow Projection

1 To create a cash flow projection, navigate to Projects

2 Select submit cash flow projection

3 Click view draft cash flow projection. You will be redirected to cash flow projections draft page.

4 If there is any pre-created Cash Flow Projections that has not been submitted, it will show on this list. Click button new projection, to create new Cash Flow Projections

The screenshot shows the NCS system interface. At the top, there is a navigation bar with 'Projects', 'Deviations', and 'Advanced Search' menus. The 'Projects' menu is open, showing options like 'View Projects', 'Submit Claim', 'View Claim Upload History', 'Submit Cashflow Projection', 'View Submitted Cashflow Projections', and 'View Draft Cashflow Projections'. A red circle '1' is over the 'Projects' menu, and a red circle '2' is over the 'Submit Cashflow Projection' option. Below the menu, there is a 'New Projection' button and a table of cash flow projections. A red circle '3' is over the 'View Draft Cashflow Projections' option. A red circle '4' is over the table. The table has columns for S/N, Submission no., Grant programme, Fiscal quarter, Created by, Projected date & time, and Status. The table contains 7 rows of data.

S/N	Submission no.	Grant programme	Fiscal quarter	Created by	Projected date & time	Status
1	NRF-000022	Reimbursement+Multiple approval+Multiple Budget+(No AI)	Q4	NCS PST HI Finance 4	15-Mar-2018	Approved
2	NRF-000021	Project with multiple budget (Reimbursement)	Q4	NCS PST HI Finance 4	09-Mar-2018	Approved
3	NRF-000020	Project with Multiple budget (Advancement) and AI	Q4	NCS PST HI Finance 4	08-Mar-2018	Approved
4	NRF-000017	Project with Single Budget	Q4	NCS PST HI Finance 4	02-Mar-2018	Rejected
5	NRF-000016	Project with Single Budget (Reimbursement) with Fellowship	Q4	NCS PST HI Finance 4	02-Mar-2018	Approved
6	NRF-000015	Project with Single Budget	Q4	NCS PST HI Finance 4	01-Mar-2018	Rejected
7	NRF-000014	Project with Single Budget	Q4	NCS PST HI Finance 4	01-Mar-2018	Pending DOR Endorsement

Create & Submit Cash Flow Projection

1 Programme Title, select programme to projected. The list is Programme ID followed by Programme Name.

2 Original budget, is total original budget per-programme for related Grantee.

3 Revised budget, is total budget after virement, per-programme for related Grantee.

4 Fiscal Year, is the financial year to be projected. This field is selected according current system date

Edit in Projection ✕

1 Programme title	120320182 : 12 march 2018 testing 2 ⓘ		
Revised budget	0 3	Original budget	57500 2
Fiscal year	FY 2018 4		
Q1		Q2	
Projections	<input type="text"/> 5	Projections	<input type="text"/>
Actuals	0 6	Actuals	0
Q3		Q4	
Projections	<input type="text"/>	Projections	<input type="text"/>
Actuals	0	Actuals	0

Cancel ✕ Save 🏠

Create & Submit Cash Flow Projection

5 Projections is for HI Finance to projected the expense in the related quarter. Projection amount need to be make for entire projects within the same grant programme.

6 Actuals, is the real expenditures occurred in entire grant programme, for each quarter. This field calculated by system and non-editable

7 To continue create a projection, click save.

8 To cancel the creation, click cancel.

The screenshot shows a web form titled "Edit in Projection" with a blue header and a close button (X) in the top right. The form contains the following fields and callouts:

- 1** Programme title: A dropdown menu showing "120320182 : 12 march 2018 testing 2" with an information icon (i).
- 3** Revised budget: A text input field containing "0".
- 2** Original budget: A text input field containing "57500".
- 4** Fiscal year: A text input field containing "FY 2018".
- 5** Q1 Projections: A text input field.
- 6** Q1 Actuals: A text input field containing "0".
- 5** Q2 Projections: A text input field.
- 6** Q2 Actuals: A text input field containing "0".
- 5** Q3 Projections: A text input field.
- 6** Q3 Actuals: A text input field containing "0".
- 5** Q4 Projections: A text input field.
- 6** Q4 Actuals: A text input field containing "0".

At the bottom right of the form, there are two buttons: "Cancel" with a close icon (X) and "Save" with a save icon (H). Callouts **8** and **7** point to the "Cancel" and "Save" buttons respectively.

Create & Submit Cash Flow Projection

1 Once record has been created and saved, the record will save in a grid view. This grid view, showing details of projections, and actuals per quarter. To continue submit Cash Flow Projection, click Next button

2 To revise created record, click hyperlink on Programme Title.

3 To delete the record, put cursor on selected record,

4 And click remove button.

Cashflow projection

[Hide Cashflow Projection Details](#)

Cashflow submission no	N/A	Fiscal year	FY 2018
Projected date and time	22-May-2018	Fiscal quarter	Q1
Status	Draft		

Cashflow projection

Cash flow projection created by programme. Please key in projected amounts for each quarter. Projection for back dated quarter is not allowed. System only allow one submission per quarter.

1 - 1 of 1 matching results found

Programme title	Conveyed budget	Q1	Q2	Q3	Q4	Total	
ASTR-PST-Programme-2	Original: 31703500.00 Revised: 0.00	Projected: 1000.00 Actual: 0.00	Projected: 2000.00 Actual: 0.00	Projected: 3000.00 Actual: 0.00	Projected: 4000.00 Actual: 0.00	Projected: 10000.00 Actual: 0.00	<input type="checkbox"/>

Remove

[Back](#) [Next](#)

Create & Submit Cash Flow Projection

1 After click next, system switch to the next page, which is undertaking page. This is a consent page before submitting projections to IGMS. Projected by, by default is HI Finance current user login.

2 Acknowledgement, select to yes, to acknowledge the submission.

3 Projected date and time, by default is current system date.

4 Select DOR name to endorse Cash Flow Projection

Cashflow projection

[Hide Cashflow Projection Details](#)

Cashflow submission no	N/A	Fiscal year	FY 2018
Projected date and time	22-May-2018	Fiscal quarter	Q1
Status	Draft		

Undertaking By HI Finance

We hereby certify that:
The cashflow projection provided above for the period stated is based on our best reasonable estimates.

Projected by: p94 - ncs 1

Projected date and time: 22-05-2018 3

Acknowledgement: Yes No 2

Name of DOR: DOR92 4

5 Comments: Please Review. |

6

[Back](#) [Save as Draft](#) [Submit](#)

Create & Submit Cash Flow Projection

5 Key in any comment if required.

6 Click submit button to continue

Cashflow projection

[Hide Cashflow Projection Details](#)

Cashflow submission no	N/A	Fiscal year	FY 2018
Projected date and time	22-May-2018	Fiscal quarter	Q1
Status	Draft		

Undertaking By HI Finance

We hereby certify that:
The cashflow projection provided above for the period stated is based on our best reasonable estimates.

Projected by	<input type="text" value="p94 - ncs"/>	Projected date and time	<input type="text" value="22-05-2018"/>
Acknowledgement	<input checked="" type="radio"/> Yes <input type="radio"/> No	Name of DOR	<input type="text" value="DOR92"/>

5 Comments

[Back](#) [Save as Draft](#) [Submit](#)

Cash Flow Projection

1. Overview and Navigation of IGMS
2. Fund Requisition (Project Claim)
 - Understanding Fund Requisition
 - Fund Requisition Type
 - Fund Requisition Period (Claim Period)
 - Fund Requisition Status
 - Fund Requisition Pages
 - Fund Requisition Navigation Bar
 - Understanding Fund Requisition Upload Process
 - Upload File Validation
 - Business Validation
 - Understanding Fund Requisition Approval

Cash Flow Projection

- Upload and Submit Fund Requisition
 - Advancement
 - Statement of Account
 - Reimbursement
- Review and Re-upload Fund Requisition (All Methods)
- Editing calculated IDC for RIE 2015

3. Cash Flow Projection

- Create & Submit Cash Flow Projection
- **Review Cash Flow Projection**

4. Download Fund Requisition

Review Cash Flow Projection

Create & Submit Cash Flow Projection

1

Cash flow projection can be returned to HI Finance. Once DOR required HI Finance to make amendment, it will appear on HI Finance dashboard. Click hyperlink on reference ID, to open returned record and make amendment.

The screenshot shows the 'Projects' section of the HI Finance dashboard. The navigation bar includes 'Dashboard', 'Projects', 'Deviations', and 'Advanced Search'. The user is logged in as 'NRF PST HI Finance 1 (HI Finance)'. The 'Projects' section displays '11 - 11 of 11 matching results found'. A table lists the following entry:

Date	Subject	Reference ID	Read
01-Jun-2020	Cash Flow Projection Pending Amendment. To view details, click on reference ID	NRF-000023	No

A red circle with the number '1' highlights the 'Reference ID' column for the first entry.

Create & Submit Cash Flow Projection

1 System redirected to cash flow projection form after click dashboard. To make amendment, click on hyperlink Programme Title.

2 Amend required amount. Then click save

Cashflow projection

[Hide Cashflow Projection Details](#)

Cashflow submission no: NRF-000019 Fiscal year: FY 2018
Projected date and time: 22-May-2018 Fiscal quarter: Q1
Status: Rejected

Cashflow projection

Cash flow projection created by programme. Please key in projected amounts for each quarter. Projection for back dated quarter is not allowed. System only allow one submission per quarter.

1 - 1 of 1 matching results found

Programme title	Conveyed budget	Q1	Q2	Q3	Q4	Total
SSAT-Programme	Original: 61703500.00 Revised: 0.00	Projected: 1.00 Actual: 0.00	Projected: 1.00 Actual: 0.00	Projected: 1.00 Actual: 0.00	Projected: 1.00 Actual: 0.00	Projected: 4.00 Actual: 0.00

[Back](#) [Edit in Projection](#) [Next](#)

Programme title: SSAT-Programme : SSAT-Programm

Revised budget: 0.00 Original budget: 61703500.00

Fiscal year: FY 2018

Q1 Projections: 1.00 Q2 Projections: 1.00
Q1 Actuals: 0.00 Q2 Actuals: 0.00

Q3 Projections: 1.00 Q4 Projections: 1.00
Q3 Actuals: 0.00 Q4 Actuals: 0.00

[Cancel](#) [Save](#)

Create & Submit Cash Flow Projection

Once amendment completed click next button to switch to undertaking page.

1

Cashflow projection

[Hide Cashflow Projection Details](#)

Cashflow submission no	NRF-000019	Fiscal year	FY 2018
Projected date and time	22-May-2018	Fiscal quarter	Q1
Status	Rejected		

Cashflow projection

Cash flow projection created by programme. Please key in projected amounts for each quarter. Projection for back dated quarter is not allowed. System only allow one submission per quarter.

1 - 1 of 1 matching results found

Programme title	Conveyed budget	Q1	Q2	Q3	Q4	Total	
SSAT-Programme	Original: 61703500.00 Revised: 0.00	Projected: 50000.00 Actual: 0.00	Projected: 1.00 Actual: 0.00	Projected: 1.00 Actual: 0.00	Projected: 1.00 Actual: 0.00	Projected: 50003.00 Actual: 0.00	<input type="checkbox"/>

[Back](#) 1 [Next](#)

Create & Submit Cash Flow Projection

On undertaking page, key in the comment if necessary.

1

And click submit to re-submit back to DOR for endorsement.

2

Cashflow projection

[^ Hide Cashflow Projection Details](#)

Cashflow submission no	NRF-000019	Fiscal year	FY 2018
Projected date and time	22-May-2018	Fiscal quarter	Q1
Status	Rejected		

Undertaking By HI Finance

We hereby certify that:

The cashflow projection provided above for the period stated is based on our best reasonable estimates.

Projected by NCS PST HI Finance 2

Projected date and time 22/05/2018

Acknowledgement Yes No

Name of DOR NCS PST DOR 2

1

Comments

Resubmit to DOR

2

[← Back](#)

[Save as Draft](#)

[Submit](#)

Download Fund Requisition

Download Fund Requisition

1. Overview and Navigation of IGMS
2. Fund Requisition (Project Claim)
 - Understanding Fund Requisition
 - Fund Requisition Type
 - Fund Requisition Period (Claim Period)
 - Fund Requisition Status
 - Fund Requisition Pages
 - Fund Requisition Navigation Bar
 - Understanding Fund Requisition Upload Process
 - Upload File Validation
 - Business Validation
 - Understanding Fund Requisition Approval

Download Fund Requisition

- Upload and Submit Fund Requisition
 - Advancement
 - Statement of Account
 - Reimbursement
- Review and Re-upload Fund Requisition (All Methods)
- Editing calculated IDC for RIE 2015

3. Cash Flow Projection

- Create & Submit Cash Flow Projection
- Review Cash Flow Projection

4. Download Fund Requisition

Download Fund Requisition

After a fund requisition is submitted, you may download the fund requisition package by initiating a download request. Follow the steps below to place the request. Note that a draft fund requisition cannot be downloaded.

1. To access the fund requisition, click **Projects > View Projects**, select the project ID and expand the *Fund Requisition* section. Select the Fund Requisition ID hyperlink
2. Open *Fund requisitions* section and click on Fund Requisition ID to be downloaded

The screenshot shows the 'Projects' dropdown menu with 'View Projects' selected. Below, the 'My projects' section displays a table of projects. The first project is highlighted with a red circle '1' around the 'Award number' field.

Project ID	Award number	Title of research project	Project start date	Project end date	Stage
1121202005-00	ASTD-048192	Design and Implementation of a New Recording Architecture for Future High-Density, Long-Term BMI ...	06-Feb-2012	05-Aug-2015	Closed

Below the table, the 'Fund requisitions' section is expanded, showing a table with one result. A red circle '2' highlights the 'Project ID' field.

Project ID	Fund requisition ID	Submission year	Submission quarter	Submission date	Status
NRF-00080	NRF-001982	FY 2019	Q3	01-Oct-2019	Pending Review

Download Fund Requisition

3 In Summary page, click on *Download Fund Request* button and system will display notification that the package will be ready in \pm 30 minutes

To Note

The package consists of below items in a “.zip” file:

- Fund Request printout (in excel format)
- Fund Request's attachment(s)
- The package will contain the latest information as of the time of placing the download.

Home > Projects > Summary

Summary ✓ Expenditure on Manpower (EOM) ✓ Other Operating Expenditure (OOE) ✓ Equipment (EQP) ✓ Overseas Travel (OT) ✓ Research Scholarship (RS) ✓ Exception Items (EI) ✓

Summary Expand All Sections

Hide Fund Details

Fund requisition ID	NRF-001982	Project ID	NRF-000807-01
Financial quarter	FY 2019 Q3	Award number	NRF-t351-0001
Submission date and time	01-Oct-2019	Project start date	01-Sep-2019
Host institution	NUS	Project end date	01-Aug-2021
HI claim no		Lead PI/Team PI	NCS PST PI 2
Status	Pending Review		

Download Fund Request

Summary ✓ Attachments ✓ Action Trail ✓ Download Fund Request ✓

Message 3

The package requested will be available for download in around 30 mins. Please access this project later to download the package.

OK ✓

Download Fund Requisition

4

After the package is ready, it will be displayed in *Download Fund Request* section. Click on the hyperlink of File name to download

Home > Projects > Submit Claim > Summary

Summary ✓ Expenditure on Manpower (EOM) ✓ Other Operating Expenditure (OOE) ✓ Equipment (EQP) ✓ Overseas Travel (OT) ✓ Research Scholarship (RS) ✓ Exception Items (EI) ✓

Summary Expand All Sections

[Hide Fund Details](#)

Fund requisition ID	NRF-001982	Project ID	NRF-000807-01
Financial quarter	FY 2019 Q3	Award number	NRF-t351-0001
Submission date and time	01-Oct-2019	Project start date	01-Sep-2019
Host institution	NUS	Project end date	01-Aug-2021
HI claim no		Lead PI/Team PI	NCS PST PI 2
Status	Pending Review		

[Download Fund Request](#)

- Summary
- Attachments
- Action Trail
- Download Fund Request

[Back](#) [Next](#)

Download Fund Request

[Download All](#)

NOTE: The attached file(s) if any will be displayed after anti-virus scan is completed. Please wait and visit this page later.

File name	Size/Status	Actions	<input type="checkbox"/> Check all
NRF-000006315.zip 05-Feb-2020 05:49 PM	10.81 KB		

4

4

SINGTEL GROUP ENTERPRISE   